

Q.bloxx A156

Measurement Module for Strain Gage and LVDT/RVDT

Q.bloxx is the ideal DAQ solution for widely distributed installations, electrical panels, and environmental enclosures. Q.bloxx measurement modules provide integrated signal conditioning and arithmetic functions, packaged in modular, DIN Rail mountable enclosures that easily snap together for quick system expansion. Flexibility in distribution allows for highly synchronized data that is less prone to noise due to shorter sensor cable runs to the actual point of measurement.

- RS 485 fieldbus interface up to 24 Mbps: LocalBus up to 115.2 kbps: Modbus-RTU, ASCII
- Electromagnetic Compatibility according to EN61000-4 and EN55011
- Connectable to any Controller, e.g. Q.station, Q.gate or Q.pac
- Power supply 10 ... 30 VDC
- DIN rail mounting (EN60715)



Key Features

- 4 galvanically isolated analog inputs channels
strain gage and inductive half and full bridges, LVDT, RVDT quarter bridge with completion terminal
- Carrier frequency (CF) principle
4.8 kHz carrier frequency
- High-accuracy digitization
24-bit ADC, 10 kHz sample rate per channel
- Signal conditioning
linearization, filtering, average, scaling, min/max, RMS, arithmetic, alarm
- 3-Way galvanic isolation
Channel to channel, channel to power supply, and channel to bus

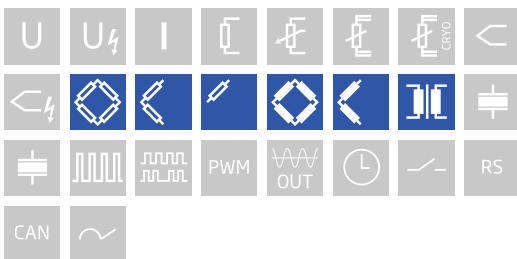

Q.bloxx A156

Measurement Module for Strain Gage and LVDT/RVDT

Block diagram

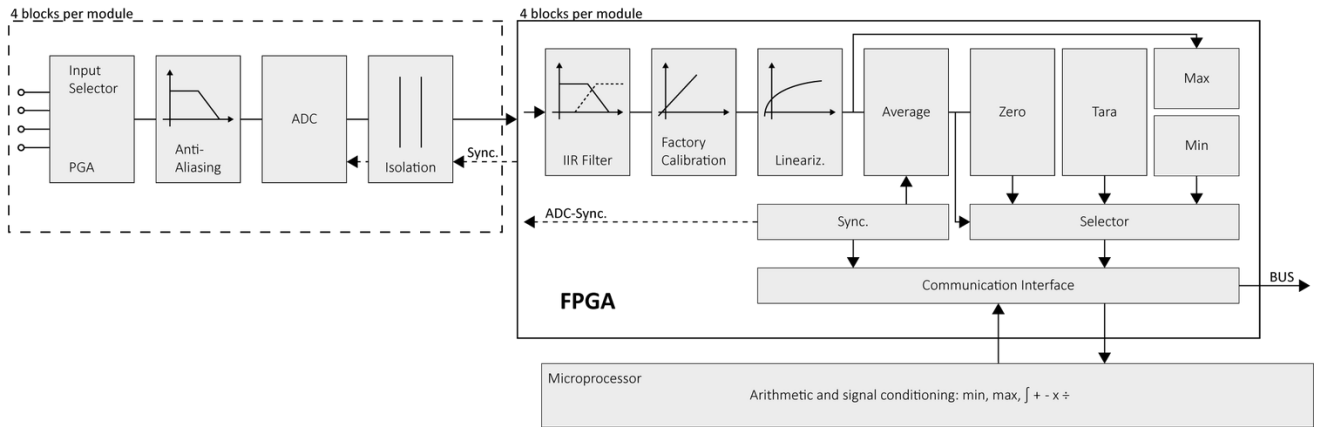

Technical Data

Terminal assignment 10pole screw

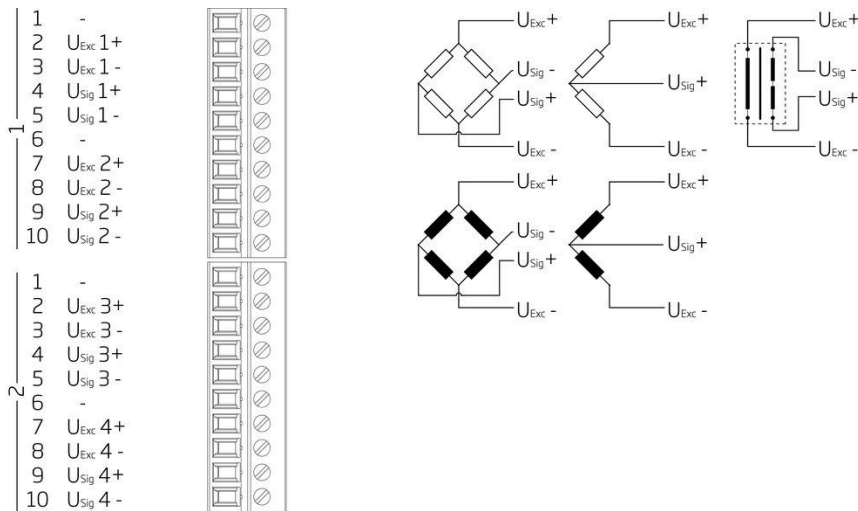

Analog Input

Channels	4
Accuracy	0.02 % typical
	0.05 % in controlled environment ¹
	0.1 % in industrial area ²
Linearity error	0.02 % typical full-scale
Repeatability	0.01 % typical (within 24 hrs)
Input impedance	>10 MΩ
Isolation voltage	500 VDC channel to channel, to power supply, channel to bus ³

¹ according to EN 61326 2006: appendix B

² according to EN 61326 2006: appendix A

³ noise pulses up to 1000 VDC, continuous up to 250 VDC

Strain Gage Measurement

Bridge configuration(s)	resistive full-bridge (4/wire) resistive half-bridge (3/wire)	
Allowable sensor cable length	< 30 m	
Shunt resistor	100 k Ω internal resistor	
Bridge excitation	2.5 or 5 V _{eff} , 4.8 kHz AC excitation	
Bridge excitation stability	< 0.01% / 24 hrs	
Bridge excitation drift	< 0.02% / 10 K	
	5 V_{eff}	2.5 V_{eff}
Allowable sensor resistance	> 300 Ω	> 100 Ω
Input range	± 1.25 mV/V	± 2.5 mV/V
	± 2.5 mV/V	± 5 mV/V
	± 25 mV/V	± 50 mV/V
	± 50 mV/V	± 100 mV/V
	± 100 mV/V	± 200 mV/V
	± 200 mV/V	± 400 mV/V
	± 500 mV/V	± 1000 mV/V
Long-term stability	< 0.1 μ V/V / 24 hrs	< 1 μ V/V / 8000 hrs
Temperature drift (range 2.5 mV/V)	< 0.2 μ V/V / 10 K Offset drift	< 0.05 % / 10 K Gain drift
Noise (range 2.5 mV/V)	0.3 μ V/V at 0 up to 10 Hz	1 μ V/V at 10 up to 1 kHz

LVDT/RVDT Measurement

Sensor connection	3- / 4-wire	
Sensor excitation (selectable)	5 V_{eff}	2.5 V_{eff}
Allowable sensor resistance	> 300 Ω	> 100 Ω
Input range	± 1.25 mV/V	± 2.5 mV/V
	± 2.5 mV/V	± 5 mV/V
	± 25 mV/V	± 50 mV/V
	± 50 mV/V	± 100 mV/V
	± 100 mV/V	± 200 mV/V
	± 200 mV/V	± 400 mV/V
	± 250 mV/V	± 500 mV/V
	± 500 mV/V	± 1000 mV/V
Allowable sensor cable length	< 100 m ¹	
Long-term stability	< 0.1 μ V/V / 24 hrs	< 1 μ V/V / 8000 hrs
Temperature drift (range 2.5 mV/V)	< 0.2 μ V/V / 10 K Offset drift	< 0.05 % / 10 K Gain drift
Signal-to-noise ratio	< 0.3 μ V/V at 10 Hz	< 1 μ V/V at 100 Hz

¹ low capacity sensor cable is strongly recommended

Measurement Module for Strain Gage and LVDT/RVDT

Analog to Digital Conversion

Resolution	24-bit
Sample rate	10 kHz per channel
Modulation method	sigma-delta
Anti-aliasing filter	1 kHz, 3rd order (4.8 kHz CF excitation)
Digital filters	Infinite impulse response (IIR), low-pass, high-pass, band-pass, band-stop, to 8th order Butterworth or Bessel, frequency range 0.1 Hz to 1 kHz in steps of 0.1 (adjustable via software)
Averaging	configurable or automatic according to the user-defined data rate

Communication Interface

Protocols	proprietary Localbus (115200 bps to 24 Mbps, latency <100 ns) ASCII (19200 bps to 115200 bps) Modbus RTU Profibus-DP (19200 bps to 12 Mbps) (special Firmware required)
Data format	8E1
Electrical standard	ANSI/TIA/EIA-485-A, 2-wire

Power Supply

Input voltage	10 to 30 VDC, overvoltage and overcurrent protection
Power consumption	2.5 W (approx.)
Input voltage influence	<0.001 % / V

Environmental Specifications

Electromagnetic compatibility (EMC)	according to IEC 61000-4 and EN 55011
Operating temperature	-20°C to +60°C
Storage temperature	-40°C to +85°C
Relative humidity	5 - 95 % at 50°C (non-condensing)

Remarks

are subject to a warm-up period of at least 45 minutes

Specifications subject to change without notice

Mechanical information

Material	Aluminum and ABS
Measurements (W x H x D)	27 x 120 x 105 mm
Weight	approx. 200 g

Ordering Information

Article number	647530
----------------	--------

Gantner Instruments

Austria | Germany | France | Sweden | India | USA | China | Singapore

office@gantner-instruments.com