



LAND



SEA



AIR

AV600-027

IP65 Military ICE LAKE-HCC XEON D-2796TE with 100G

MPO QSFP28 GPU Server



- MIL-STD 810 Thermal, Shock, Vibration, Humidity
- MIL-STD 461 EMI / EMC
- Intel® Ice Lake-HCC Xeon-D2796TE Processors, up to 20 cores
- Throughput 50Gbps and 100Gbps (4 x 25Gbps)
D38999 MPO LAN Port
- NVIDIA RTX™ A2000 8GB GDDR6 memory
- Up to 256GB DDR4 RDIMM, 512G DDR4 LRDIMM
2560 CUDA cores
- IP65 1 x 2.5" SATA SSD Easy Swap Tray
- MIL-STD-461/1275 18V~36V DC-Input

Specifications

System

Processors	Intel® Xeon® D2796TE, 20core, 40 thread, 30MB Cache, 2.0/3.1GHz. Single socket FCBGA-2579 , up to 118W TDP
Memory type	Up to 256GB ECC RDIMM DDR4-3200 MT/s Up to 512GB LRDIMM DDR4-3200 MT/s
Chipset	Intel® SoC Integrated
GPU	1x NVidia® RTX A2000, 2560 CUDA Cores
Display	VGA, Resolution up to 1920x1200@60Hz 32bpp
Display Chipset	Aspeed AST2510
Ethernet Controller	10G /25G SFP28 LAN from CPU ETH_KR Gigabit LAN via Intel®I210iT
LAN	4 x 25GBase SFP28
Storage	1 x M.2 NVMe 2TB M2. 2280 Gen4 x 4 SSD 2 x U.2 NVMe 8TB 2.5" SSD
Power Type	MIL-STD-461 / 1275 18V~36V DC Input
Dimension	400 mm x 360 mm x 100 mm (W x L x H)

Front I/O

DC-IN	1x DC-IN, with D38999 connector
X1	2x RS232, with D38999 connector
X2	1x MPO with 4x 25GbE SFP28, with D38999 connector
X3	1x MiniDP, with D38999 connector (Internal VGA to MiniDP)
X4	1x USB3.0 , with D38999 connector
LED	1x SSD/HDD LED indicator
switch	1x IP65 power button , with LED indicator
SSD	1 x 2.5"Easy swap SSD Tray

Power

Power input	MIL-STD-461 18V~36V DC-Input
-------------	------------------------------

Physical

Dimension	250(W) x 400 (L) x 122 (H)mm
Chassis	Aluminum Ally

Heatsink Heatsink Aluminum Alloy with air cooler, Corrosion Resistant

Environmental

Green Product RoHS, WEEE compliance

Operating Temp. -40°C to +60°C

Storage Temp. -40°C to +85°C

Relative Humidity 5% to 95%, non-condensing

MIL-STD-810 Specifications

Method 500.5, Procedures I and II (Altitude) :

12,192 M, (40,000 ft) for the initial cabin altitude (18.8 Kpa or 2.73 Psia)

Method 500.5, Procedures III and IV (Altitude, Non-Operation):

15,240, (50,000 ft) for the initial cabin altitude (14.9 Kpa or 2.16 Psia)

Method 501.5, Procedure I (Storage/High Temperature)

Method 501.5, Procedure II (Operation/High Temperature)

Method 502.5, Procedure I (Storage/Low Temperature)

Method 502.5, Procedure II (Operation/Low Temperature)

Method 503.5, Procedure I (Temperature shock)

Method 507.5, Procedure II (Temperature & Humidity)

Method 509.7 Salt Spray (50±5)g/L

Method 514.6, Vibration Category 24/Non-Operating (Category 20 & 4,Vibration)

Method 514.6, Vibration Category 20/Operating (Category 20 & 24,Vibration)

Method 516.6, Shock-Procedure V Non-Operating (Mechanical Shock)

Method 516.6, Shock-Procedure I Operating (Mechanical Shock)

MIL-STD-461

CE102 basic curve, 10 kHz - 30 MHz

RE102-4, (1.5 MHz) -30 MHz - 5 GHz

RS103, 200 MHz - 3.2 GHz, 50 V/m equal for all frequencies

EN 61000-4-2: Air discharge: 8 kV, Contact discharge: 6kV

EN 61000-4-3: 10 V/m, EN 61000-4-4: Signal and DC-Net: 1 kV

EN 61000-4-4: Signal and DC-Net: 1 kV

EN 61000-4-5: Leads vs. ground potential 1kV, Signal und DC-Net: 0.5 kV

EN55022 : Class A

MIL-STD-1275

Steady State – 20V~33V

Surge Low – 18V/500ms

Surge High – 100V/500ms

Operating System

Operating System Windows 10 64Bit, Linux by option

RoHS RoHS compliant

Ordering Information

IP65 Military GPU Server Intel® ICE LAKE-HCC XEON D-2796TE, up to 256GB ECC RDIMM / 512GB LRDIMM DDR4 3200 MHz , 1 x 100G (Cable Kit MPO to 4 x 25G SFP28), 2 x COM, 1 x USB3.0, 1 x MiniDP , MXM GPU RTX A2000, MIL-STD-461/1275 Power DC-IN 18~36V, Operation Temp. -40°C to 60°C, RoHS

		AV600-D27
CPU		Intel® Xeon® D2796TE(20C)
RAM		Up to 256GB ECC RDIMM, DDR4-3200MHz; Up to 512GB LRDIMM , DDR4-2667MHz
RAID		RAID 0/1/5/10
Storage		2 x 2.5" U.2 NVMe 8TB 1 x M.2 NVMe 2TB
I/O	X1	2 x RS232
	X2	1x MPO with 4x 25GbE SFP28
	X3	1 x MiniDP
	X4	1 x USB3.0
		1 x DC-IN
		1 x Swap SSD Tray

Block Diagram

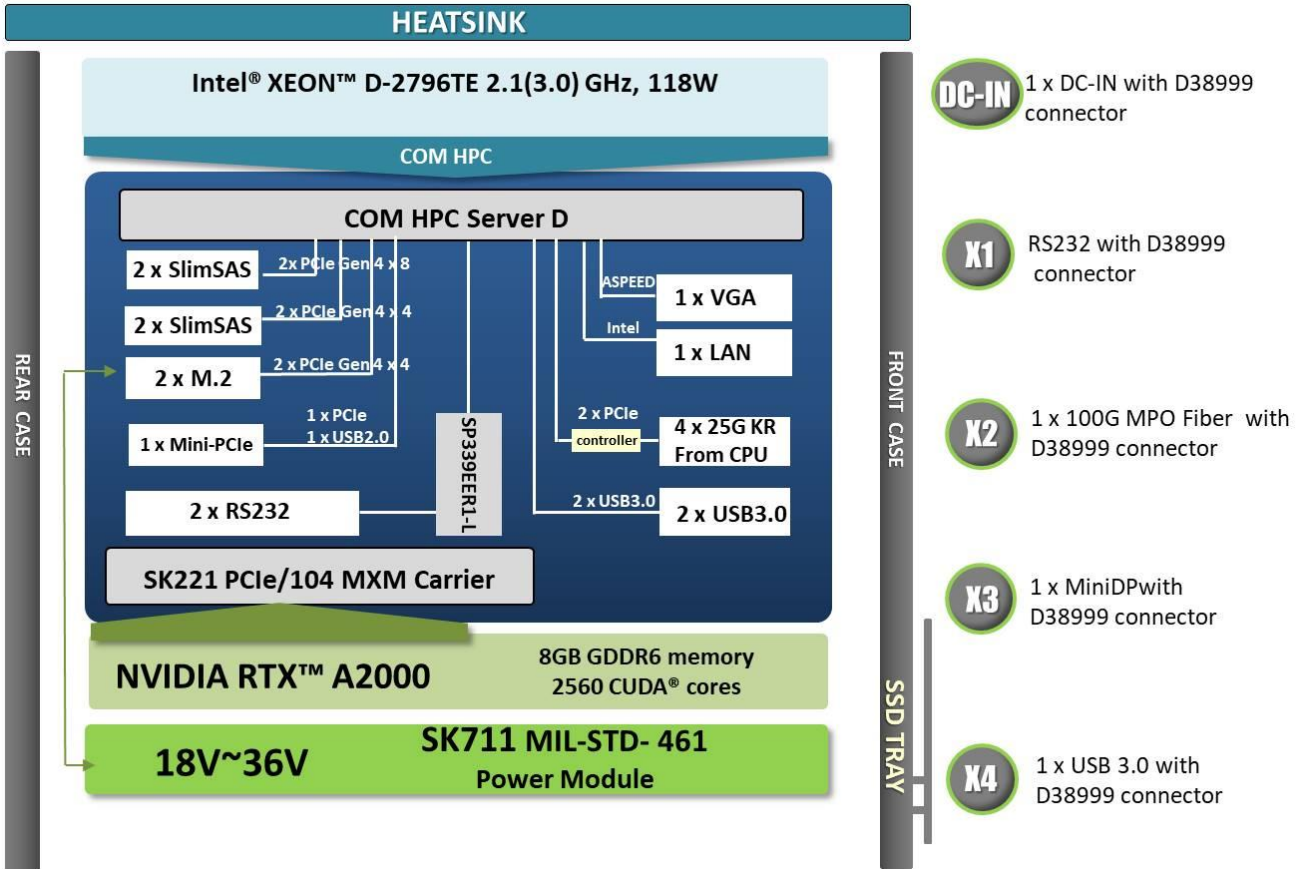

Appearance



Dimension

