

User Manual

# UNO-2372G V2

電腦

Intel® Celeron® Small-Sized  
Automation Computer with 2 x  
GbE, 1 x mPCIe, 1 x M.2 B key, 1x  
M.2 M key, 3 x USB3.2,  
1 x USB2.0, 1 x HDMI 1.4,  
1 x DP 1.2, and 4 x COM

**ADVANTECH**

*Enabling an Intelligent Planet*

## Copyright

The documentation and the software included with this product are copyrighted 2022 by Advantech Co., Ltd. All rights are reserved. Advantech Co., Ltd. reserves the right to make improvements in the products described in this manual at any time without notice. No part of this manual may be reproduced, copied, translated, or transmitted in any form or by any means without the prior written permission of Advantech Co., Ltd. The information provided in this manual is intended to be accurate and reliable. However, Advantech Co., Ltd. assumes no responsibility for its use, nor for any infringements of the rights of third parties that may result from its use.

## Acknowledgments

Intel<sup>®</sup>, Celeron<sup>™</sup> are the trademarks of Intel<sup>®</sup> Corporation.

Microsoft Windows and MS-DOS are registered trademarks of Microsoft Corp.

All other product names or trademarks are properties of their respective owners.

## Support

For more information on this and other Advantech products, please visit our website at <http://www.advantech.com>

For technical support services, please visit our support website at <http://support.advantech.com/>

This manual applies to the following models. These are abbreviated as UNO-2372G V2 products in this article.

\*Model name:

UNO-2372G V2

\*Part number:

UNO-2372G-J231AE	UNO-2372G-J231AU	UNO2372GJ2312201-T
UNO2372GJ2312202-T	UNO2372GJ2312203-T	UNO2372GJ2312204-T
UNO2372GJ2312205-T	UNO2372GJ2312206-T	UNO2372GJ2312207-T
UNO2372GJ2312208-T	UNO2372GJ2312209-T	UNO2372GJ2312210-T
UNO2372GJ2312211-T	UNO2372GJ2312212-T	UNO2372GJ2312213-T
UNO2372GJ2312214-T	UNO2372GJ2312215-T	UNO2372GJ2312301-T
UNO2372GJ2312302-T	UNO2372GJ2312303-T	UNO2372GJ2312304-T
UNO2372GJ2312305-T	UNO2372GJ2312306-T	UNO2372GJ2312307-T
UNO2372GJ2312308-T	UNO2372GJ2312309-T	UNO2372GJ2312310-T
UNO2372GJ2312311-T	UNO2372GJ2312312-T	UNO2372GJ2312313-T
UNO2372GJ2312314-T	UNO2372GJ2312315-T	UNO2372GJ2312316-T
UNO2372GJ2312317-T	UNO2372GJ2312318-T	UNO2372GJ2312319-T
UNO2372GJ2312320-T	UNO2372GJ2312401-T	UNO2372GJ2312402-T
UNO2372GJ2312403-T	UNO2372GJ2312404-T	UNO2372GJ2312405-T
UNO2372GJ2312406-T	UNO2372GJ2312407-T	UNO2372GJ2312408-T
UNO2372GJ2312409-T	UNO2372GJ2312410-T	UNO2372GJ2312411-T
UNO2372GJ2312412-T	UNO2372GJ2312413-T	UNO2372GJ2312414-T

Part No. 2004237200

Edition 1

November 2022

UNO2372GJ2312415-T	UNO2372GJ2312416-T	UNO2372GJ2312417-T
UNO2372GJ2312418-T	UNO2372GJ2312419-T	UNO2372GJ2312420-T
UNO2372GJ2312501-T	UNO2372GJ2312502-T	UNO2372GJ2312503-T
UNO2372GJ2312504-T	UNO2372GJ2312505-T	UNO2372GJ2312506-T
UNO2372GJ2312507-T	UNO2372GJ2312508-T	UNO2372GJ2312509-T
UNO2372GJ2312510-T	UNO2372GJ2312511-T	UNO2372GJ2312512-T
UNO2372GJ2312513-T	UNO2372GJ2312514-T	UNO2372GJ2312515-T
UNO2372GJ2312516-T	UNO2372GJ2312517-T	UNO2372GJ2312518-T
UNO2372GJ2312519-T	UNO2372GJ2312520-T	UNO2372GJ2312601-T
UNO2372GJ2312602-T	UNO2372GJ2312603-T	UNO2372GJ2312604-T
UNO2372GJ2312605-T	UNO2372GJ2312606-T	UNO2372GJ2312607-T
UNO2372GJ2312608-T	UNO2372GJ2312609-T	UNO2372GJ2312610-T
UNO2372GJ2312611-T	UNO2372GJ2312612-T	UNO2372GJ2312613-T
UNO2372GJ2312614-T	UNO2372GJ2312615-T	UNO2372GJ2312616-T
UNO2372GJ2312617-T	UNO2372GJ2312618-T	UNO2372GJ2312619-T
UNO2372GJ2312620-T	UNO2372GJ2312701-T	UNO2372GJ2312702-T
UNO2372GJ2312703-T		

## Product Warranty (2 years)

Advantech warrants the original purchaser that each of its products will be free from defects in materials and workmanship for two years from the date of purchase.

This warranty does not apply to any products that have been repaired or altered by persons other than repair personnel authorized by Advantech, or products that have been subject to misuse, abuse, accident, or improper installation. Advantech assumes no liability under the terms of this warranty as a consequence of such events.

Because of Advantech's high quality-control standards and rigorous testing, most customers never need to use our repair service. If an Advantech product is defective, it will be repaired or replaced free of charge during the warranty period. For out-of-warranty repairs, customers will be billed according to the cost of replacement materials, service time, and freight. Please consult your dealer for more details.

If you believe your product to be defective, follow the steps outlined below.

1. Collect all the information about the problem encountered. (For example, CPU speed, Advantech products used, other hardware and software used, etc.) Note anything abnormal and list any onscreen messages displayed when the problem occurs.
2. Call your dealer and describe the problem. Please have your manual, product, and any helpful information readily available.
3. If your product is diagnosed as defective, obtain a return merchandise authorization (RMA) number from your dealer. This allows us to process your return more quickly.
4. Carefully pack the defective product, a completed Repair and Replacement Order Card, and a proof of purchase date (such as a photocopy of your sales receipt) into a shippable container. Products returned without a proof of purchase date are not eligible for warranty service.
5. Write the RMA number clearly on the outside of the package and ship the package prepaid to your dealer.

---

# Declaration of Conformity

## CE

This product has passed the CE test for environmental specifications when shielded cables are used for external wiring. We recommend the use of shielded cables. This type of cable is available from Advantech. Please contact your local supplier for ordering information.

Test conditions for passing also include the equipment being operated within an industrial enclosure. In order to protect the product from damage caused by electrostatic discharge (ESD) and EMI leakage, we strongly recommend the use of CE-compliant industrial enclosure products.

## FCC Class A

This equipment has been tested and found to comply with the limits for a Class A digital device, pursuant to part 15 of the FCC Rules. These limits are designed to provide reasonable protection against harmful interference when the equipment is operated in a commercial environment. This equipment generates, uses, and can radiate radio frequency energy and, if not installed and used in accordance with the instruction manual, may cause harmful interference to radio communications. Operation of this equipment in a residential area is likely to cause harmful interference. In this event, users are required to correct the interference at their own expense.

## 警告使用者

此為甲類資訊技術設備，於居住環境中使用時，可能會造成射頻擾動，在此種情況下，使用者會被要求採取某些適當的對策。

# Technical Support and Assistance

1. Visit the Advantech website at [www.advantech.com/support](http://www.advantech.com/support) to obtain the latest product information.
2. Contact your distributor, sales representative, or Advantech's customer service center for technical support if you need additional assistance. Please have the following information ready before calling:
  - Product name and serial number
  - Description of your peripheral attachments
  - Description of your software (operating system, version, application software, etc.)
  - A complete description of the problem
  - The exact wording of any error messages

## Safety Precautions - Static Electricity

Follow these simple precautions to protect yourself from harm and the products from damage.

- To avoid electrical shock, always disconnect the power from the PC chassis before manual handling. Do not touch any components on the CPU card or other cards while the PC is powered on.
- Disconnect the power before making any configuration changes. A sudden rush of power after connecting a jumper or installing a card may damage sensitive electronic components.

## Safety Instructions

1. Read these safety instructions carefully.
2. Retain this user manual for future reference.
3. Disconnect the equipment from all power outlets before cleaning. Use only a damp cloth for cleaning. Do not use liquid or spray detergents.
4. For pluggable equipment, the power outlet socket must be located near the equipment and easily accessible.
5. Protect the equipment from humidity.
6. Place the equipment on a reliable surface during installation. Dropping or letting the equipment fall may cause damage.
7. The openings on the enclosure are for air convection. Protect the equipment from overheating. Do not cover the openings.
8. Ensure that the voltage of the power source is correct before connecting the equipment to a power outlet.
9. Position the power cord away from high-traffic areas. Do not place anything over the power cord.
10. All cautions and warnings on the equipment should be noted.
11. If the equipment is not used for a long time, disconnect it from the power source to avoid damage from transient overvoltage.
12. Never pour liquid into an opening. This may cause fire or electrical shock.
13. Never open the equipment. For safety reasons, the equipment should be opened only by qualified service personnel.
14. If any of the following occurs, have the equipment checked by service personnel:
  - The power cord or plug is damaged.
  - Liquid has penetrated the equipment.
  - The equipment has been exposed to moisture.
  - The equipment is malfunctioning, or does not operate according to the user manual.
  - The equipment has been dropped and damaged.
  - The equipment shows obvious signs of breakage.
15. Do not leave the equipment in an environment with a storage temperature of below  $-40^{\circ}\text{C}$  ( $-40^{\circ}\text{F}$ ) or above  $85^{\circ}\text{C}$  ( $185^{\circ}\text{F}$ ) as this may damage the components. The equipment should be kept in a controlled environment.
16. **CAUTION:** Batteries are at risk of exploding if incorrectly replaced. Replace only with the same or equivalent type as recommended by the manufacturer. Discard used batteries according to the manufacturer's instructions.
17. In accordance with IEC 704-1:1982 specifications, the sound pressure level at the operator's position does not exceed 70 dB (A).

18. This product is intended to be supplied by an UL certified power supply or dc source with SELV output, rated 10 Vdc, 5.4 A minimum and Tma 40 degree. If you need further assistance, please contact Advantech for further information.
19. Ensure that the voltage of the power source is correct before connecting the equipment to a power outlet. The power outlet socket should have a grounded connection.
20. For use in pollution free environments and indoor use.
21. This equipment is not suitable for use in locations where children are likely to be present.
22. If the equipment is used in a manner not specified by the Advantech, the protection provided by the equipment may be impaired.
23. The equipment contains no user-serviceable parts. Do not open, Return to manufacturer for servicing.
24. Do not block air ventilation holes.
25. This is open type equipment and should be installed in a suitable enclosure.
26. Restricted Access Area: The equipment should only be installed in a Restricted Access Area.
27. This product is intended to be supplied by an UL Listed power supply suitable for use at Tma 60° C min. whose output meets ES1 (or SELV) is rated: (1) 10-36Vdc, 5.5-1.53A min. (DC IN), if need further assistance, please contact Advantech for further information.



Caution: Hot surface. Do not touch for Top Heatsink.

DISCLAIMER: These instructions are provided according to IEC 704-1 standards. Advantech disclaims all responsibility for the accuracy of any statements contained herein.

## Consignes de sécurité

1. Lire attentivement les instructions de sécurité.
2. Conserver ce manuel pour utilisation ultérieure,
3. Débranchez cet équipement de toute prise secteur avant le nettoyer. Utilisez seulement un chiffon humide. N'utilisez pas de détergent liquide ou pulvérisé pour le nettoyage.
4. Gardez cet équipement à l'abri de l'humidité.
5. Placez cet équipement sur une surface fiable pendant l'installation. Le faire ou bien le laisser tomber peut causer des dégâts.
6. Les ouvertures sur l'enceinte servent à la convection de l'air. Protégez l'équipement contre surchauffe. **NE COUVREZ PAS LES OUVERTURES.**
7. Assurez-vous que la tension de la source d'alimentation est correcte avant de connecter l'équipement à une prise de courant. La prise de courant doit avoir une connexion à la terre.
8. Placez le câble d'alimentation de manière à ce que personne ne puisse marcher dessus. Ne placez rien sur le câble d'alimentation.
9. Toutes les mises en garde et tous les avertissements sur l'équipement doivent être notés.
10. Si l'équipement n'est pas utilisé pendant une longue période, débranchez-le de la source d'alimentation pour éviter tout endommagement dû à une surtension transitoire.

11. Ne jamais verser de liquide dans une ouverture. Cela pourrait provoquer un incendie ou un choc électrique.
12. N'ouvrez jamais l'équipement. Pour des raisons de sécurité, l'équipement doit être ouvert uniquement par du personnel qualifié.
13. Si l'une des situations suivantes se présente, faites vérifier l'équipement par le personnel de service:
  - un liquide a pénétré dans l'équipement.
  - L'équipement a été exposé à l'humidité.
  - L'équipement ne fonctionne pas bien, ou vous ne pouvez pas le faire fonctionner selon le manuel de l'utilisateur.
  - L'équipement ne fonctionne pas bien, ou vous ne pouvez pas le faire fonctionner selon le manuel d'utilisation.
  - L'équipement est tombé et endommagé.
  - L'équipement présente des signes évidents de rupture.
14. NE LAISSEZ PAS CET ÉQUIPEMENT DANS UN ENVIRONNEMENT OU LA TEMPÉRATURE DE STOCKAGE PEUT ÊTRE INFÉRIEURE À -40° C (-40° F) OU BIEN SUPÉRIEURE À 85° C (185° F). CECI POURRAIT ENDOMMAGER L'EQUIPEMENT. L'ÉQUIPEMENT DEVRAIT ÊTRE DANS UN ENVIRONNEMENT CONTRÔLÉ.
15. Ce produit est destiné à être alimenté par une source d'alimentation certifiée UL ou par une source cc convenant à une utilisation à une température minimale de 40 degrés Celsius, dont la sortie est conforme à la norme SELV et dont la puissance nominale est de 10 Vdc, 5.4 A, en cas de besoin. contactez Advantech pour plus d'informations.
16. Pour une utilisation dans des environnements non polluant et à l'intérieur.
17. C'est appareil ne doit pas être utilisé dans des endroits où se trouvent des enfants.
18. Si l'équipement est utilisé d'une manière non spécifiée par le fabricant, la protection fournie par l'équipement peut être altéré.
19. L'équipement ne contient aucune pièce réparable par l'utilisateur. Ne pas ouvrir, retourner au fabricant pour réparation.
20. Ne bloquez pas les ou es de ventilation.
21. Il s'agit d'un équipement de type ouvert et doit être installé dans un boîtier approprié.



Attention: Surface chaude, ne pas toucher pour le dissipateur thermique supérieur.

22. **ATTENTION:** Danger d'explosion si la batterie est mal remplacée. Remplacer uniquement par le même type ou équivalent recommandé par le fabricant. Jeter les piles usagées selon les instructions du fabricant.

## 安全指示

1. 請仔細閱讀此安全操作說明。
2. 請妥善保存此用戶手冊供日後參考。
3. 用濕抹布清洗設備前，請確認拔除電源線。請勿使用液體或去污噴霧劑清洗設備。
4. 對於使用電源線的設備，設備周圍必須有容易接觸到的電源插座。
5. 請勿在潮濕環境中試用設備。
6. 請在安裝前確保設備放置在可靠的平面上，意外摔落可能會導致設備損壞。
7. 設備機殼的開孔適用於空氣對流，從而防止設備過熱。請勿覆蓋開孔。
8. 當您連接設備到電源插座前，請確認電源插座的電壓符合要求。
9. 請將電源線佈置在人們不易絆倒的位置，請勿在電源線上覆蓋任何雜物。
10. 請注意設備上所有的警告標示。
11. 如果長時間不使用設備，請拔除與電源插座的連結，避免設備被超標的電壓波動損壞。
12. 請勿讓任何液體流入通風口，以免引起火災或短路。
13. 請勿自行打開設備。為了確保您的安全，請透過經認證的工程師來打開設備。
14. 如遇下列情況，請由專業人員維修：
  - 電源線或插頭損壞；
  - 設備內部有液體流入；
  - 設備曾暴露在過度潮濕環境中使用；
  - 設備無法正常工作，或您無法透過用戶手冊來正常工作；
  - 設備摔落或損壞；
  - 設備有明顯外觀損；
15. 請勿將設備儲存在超出建議溫度範圍的環境，即不要低於  $-40^{\circ}\text{C}$  ( $-40^{\circ}\text{F}$ ) 或高於  $85^{\circ}\text{C}$  ( $185^{\circ}\text{F}$ )，否則可能會造成設備損壞。
16. 注意：若電池更換不正確，將有爆炸危險。因此，只可以使用製造商推薦的同一種或者同等型號的電池進行替換。請按照製造商的指示處理舊電池。
17. 根據 IEC 704 - 1:1982 規定，操作員所在位置音量不可高於 70 分貝。
18. 限制區域：請勿將設備安裝於限制區域使用。
19. 免責聲明：請安全訓示符合 IEC 704 - 1 要求。研華公司對其內容之準確性不承擔任何法律責任。
20. 消費者若使用電源适配器供电，则应购买配套使用获得 CCC 认证并满足标准要求的电源适配器。



警告：機殼高溫。請勿在使用過程中觸碰上方散熱鰭片。

21. 警告：為避免電磁干擾，本產品不應安裝或使用於住宅環境。
22. 本產品於國內裝置使用時，其電源僅限使用機架電源模組所提供之直流電源輸入，不得使用交流電源及附加其他電源轉換裝置提供電源，其電源輸入電壓及電流請依說明書規定使用。



設備名稱：電腦		型號（型式）：UNO-2372G V2（系列型號請參見手冊載明型號）				
Equipment name		Type designation (Type)				
單元 Unit	限用物質及其化學符號 Restricted substances and its chemical symbols					
	鉛 Lead (Pb)	汞 Mercury (Hg)	鎘 Cadmium (Cd)	六價鉻 Hexavalent chromium (Cr <sup>+6</sup> )	多溴聯苯 Polybrominated biphenyls (PBB)	多溴二苯醚 Polybrominated Diphenyl ethers (PBDE)
電路板	-	○	○	○	○	○
內外殼（外殼、內部框架…等）	○	○	○	○	○	○
其它固定組件（螺絲）	-	○	○	○	○	○
配件（線材）	○	○	○	○	○	○
記憶卡	-	○	○	○	○	○
<p>備考 1. “超出 0.1 wt %” 及 “超出 0.01 wt %” 係指限用物質之百分比含量超出百分比含量基準值。  Note 1: “Exceeding 0.1 wt %” and “exceeding 0.01 wt %” indicate that the percentage content of the restricted substance exceeds the reference percentage value of presence condition.</p> <p>備考 2. “○” 係指該項限用物質之百分比含量未超出百分比含量基準值。  Note 2: “○” indicates that the percentage content of the restricted substance does not exceed the percentage of reference value of presence.</p> <p>備考 3. “-” 係指該項限用物質為排除項目。  Note 3: The “-” indicates that the restricted substance corresponds to the exemption.</p>						



# Contents

<b>Chapter 1</b>	<b>Overview.....</b>	<b>1</b>
1.1	Introduction .....	2
1.2	Safety Precautions .....	2
1.3	Packing List.....	3
1.4	Hardware Specifications .....	3
1.4.1	General .....	3
1.4.2	System Hardware .....	3
1.4.3	I/O Interfaces .....	3
1.4.4	Environment.....	4
1.4.5	Certification.....	4
1.4.6	Extension Kit (Optional).....	4
1.5	Dimensions .....	5
	Figure 1.1 UNO-2372G V2 Dimensions .....	5
	Figure 1.2 UNO-2372G V2 Dimensions (with Optional Extension Kit).....	5
<b>Chapter 2</b>	<b>Hardware Functionality.....</b>	<b>7</b>
2.1	Introduction .....	8
	Figure 2.1 Front Panel of UNO-2372G V2.....	8
	Figure 2.2 Rear Panel of UNO-2372G V2 .....	8
2.2	Serial Communication Ports.....	8
2.2.1	COM Port Interfaces (COM1, COM2, COM3, COM4) .....	8
2.2.2	Power Connector .....	8
2.2.3	LAN: Ethernet Connector.....	8
2.2.4	USB Connector.....	9
2.2.5	HDMI Connector .....	9
2.2.6	DP Connector .....	9
2.2.7	RTC Battery .....	9
2.2.8	Power Button/Power Management .....	9
2.2.9	Reset Button .....	9
2.2.10	mPCIe Connector .....	9
2.2.11	M.2 B-key Connector .....	9
2.2.12	M.2 M-key Connector.....	10
2.2.13	Nano SIM Slot.....	10
2.2.14	LED Indicators .....	10
	Figure 2.3 LED Indicators, Reset Buttons, and Antenna Hole...	10
2.3	Base Unit's Internal Connectors.....	11
	Figure 2.4 Diagram of Connector Locations on UNO-2372G V2 (Top Side).....	11
	Figure 2.5 Diagram of Key Components Location on UNO-2372G V2 (Bottom Side) .....	11
	Table 2.1: Key Components, Connectors on Mother Board.....	12
<b>Chapter 3</b>	<b>Initial Setup .....</b>	<b>13</b>
3.1	Chassis Grounding.....	14
	Figure 3.1 Chassis Grounding Connection Diagram .....	14
3.2	Connecting Power .....	14
3.3	Open and Close Bottom Cover .....	15
3.4	Installing 2.5" HDD/SSD (height is within 7mm).....	17
3.5	Installing 2.5" HDD/SSD (height is within 7mm) on 2nd stack .....	18
3.6	Installing Internal Component .....	19

3.6.1	Installing M.2 2242 Card.....	19
3.6.2	Installing M.2 M key 3042 Card .....	20
3.6.3	Installing M.2 B Key 3042 Card .....	20
3.6.4	Installing M.2 B Key 3052 Card .....	20
3.6.5	Installing the mPCIe Module .....	21
3.7	Antenna Installation (Optional).....	21
3.8	BIOS Setting .....	22

## Appendix A System Settings/Pin Assignments .. 23

A.1	Power Connector (DCIN1).....	24
	Table A.1: Power Connector Pin Assignments.....	24
A.2	LAN: Ethernet Connector (LAN1) .....	24
	Table A.2: Ethernet Connector Pin Assignments .....	24
A.3	USB Connector (USB3C1/USB3C2).....	25
A.3.1	USB 3.0 Connector.....	25
	Table A.3: USB 3.0 Connector Pin Assignments.....	25
A.4	HDMI Connector (DP1).....	26
	Table A.4: Display Port Adapter Cable Pin Assignments .....	26
A.5	M.2 B-key Connector (M2_B1) .....	27
	Table A.5: M.2 B Key Connector Pin Assignments .....	27
A.6	M.2 M-Key Connector (M2_M1).....	28
	Table A.6: M.2 M key Connector Pin Assignments .....	28
A.7	mPCIe Connector (MINIPCIE1).....	30
	Table A.7: mPCIe Connector Pin Assignments .....	30
A.8	COM Port RS232/422/485 Settings .....	31
A.9	AT/ATX Setting (PSON2).....	31
A.10	SW1 .....	32
A.11	JCMOS Clear Function .....	32
A.12	TPM 2.0 BIOS Setting.....	33
A.13	CPU Turbo Mode BIOS Setting .....	35

# Chapter 1

## Overview

This chapter overviews specifications for UNO-2372G V2.

- Introduction
- Safety Precautions
- Accessories
- Hardware Specifications
- Dimensions

## 1.1 Introduction

Advantech's new UNO-2 series serve as modular Integrated Edge Controllers. They provide configuration flexibility for customers seeking to cost effectively optimize their services. The new integrated Din-rail mounting kit is designed to be more ruggedized and user-friendly, making it a perfect fit for control cabinets.

This new UNO-2372 V2 model features a ruggedized design with an industrial-grade Intel Celeron® J6412 2.0GHz, and 4GB or 8GB DDR4 RAM. It supports wide temperature range operation (-20 ~ 60° C/-4 ~ 140° F) and sufficient I/O - including 2 x LAN, 3 x USB 3.2, 1 x USB2.0, 1 x HDMI 1.4, 1 x DP 1.4, 4 x COM, 1 x 2 pin terminal block. It also supports 1 x full-size Mini PCIe slot (PCIe/USB2.0 signal) to enable expansion. An optional 2nd stack extension kit supports 2 x iDoor module, such as industrial Fieldbus, as well as I/O and peripheral modules. This expandability makes Advantech's UNO-2 series an excellent choice for various industrial applications. Additionally, UNO-2's flexible expandability and control functions meet emerging demands for industry 4.0.

## 1.2 Safety Precautions

Below are a few safety precautions for preventing injury when making connections. In most cases, users can use a standard cable for connection.

**Warning!** *Always disconnect the power cord from the chassis before manual handling. Do not connect the chassis while the system power is on. A sudden rush of power can damage sensitive electronic components. Only experienced electronics personnel should open the chassis.*



**Warning!** *Toujours à la terre pour éliminer toute charge d'électricité statique avant toucher UNO-2372G V2. Appareils électroniques modernes sont très sensibles à charges d'électricité statique. Utilisez un bracelet antistatique à tout moment. Placez tous composants électroniques sur une surface antistatique ou dans un statique-sac blindé.*



**Caution!** *Always ground yourself to remove any static electric charge before touching UNO-2372G V2. Modern electronic devices are very sensitive to static electric charges. Use a grounding wrist strap at all times. Place all electronic components on a static-dissipative surface or in a static shielded bag.*



**Caution!** *Toujours débrancher le cordon d'alimentation de votre boîtier lorsque vous êtes travailler. Ne branchez pas lorsque l'appareil est allumé. Un afflux soudain de puissance peut endommager les composants électroniques sensibles. Seulement connu personnel de l'électronique devraient ouvrir le châssis.*



## 1.3 Packing List

Please refer to below packing list:

- 1 x UNO-2372G V2
- 1 x plug-in block for power wiring
- 1 x SATA cable (Advantech P/N:1700027329-31)
- 4 x screws for attaching HDD (Advantech P/N:1930001361)
- Quick Start Guide
- 1 x Warranty card

If anything is missing or damaged, contact your distributor or sales representative immediately.

## 1.4 Hardware Specifications

### 1.4.1 General

<b>Dimensions (W x D x H)</b>	35 x 105 x 150 mm (5.8 x 4.2 x 1.4 in)
<b>Weight (Net)</b>	0.8 kg (1.8 lbs)
<b>Mounting</b>	Stand/Wall mount
<b>Power Requirement</b>	10 - 36V <sub>DC</sub>
<b>Power Consumption</b>	19W (typical), 54W (Max)

### 1.4.2 System Hardware

<b>BIOS</b>	AMI EFI X64
<b>Watchdog Timer</b>	Programmable 255 levels timer interval, from 1 to 255 sec
<b>Hardware Security</b>	TPM 2.0
<b>Processor</b>	Intel Celeron <sup>®</sup> J6412 2.0GHz (max. turbo 2.6 GHz)
<b>Memory</b>	8GB DDR4 3200MHz (Up to 32GB)
<b>Graphics Engine</b>	Intel <sup>®</sup> UHD Graphics for 10th Gen Intel <sup>®</sup> Processors
<b>Ethernet</b>	Ethernet Controller Realtek 8119i
<b>LED Indicators</b>	1 x Battery, 1x Storage, 1 x Power, and LAN (active, status)
<b>Storage</b>	1 x 2.5" SATA HDD drive bay (max. height 9.5 mm)
<b>Expansion</b>	1 x mPCIe (PCIe/USB2.0) 1 x M.2 B key (USB3.0) 1 x M.2 M key (PCIex2/SATA)

### 1.4.3 I/O Interfaces

<b>LAN Ports</b>	2 x RJ45, 10/100/1000 Mbps IEEE 802.3u 1000BASE-T Fast Ethernet
<b>USB Ports</b>	3 x USB 3.2 GEN1, 1 x USB2.0
<b>Displays</b>	1 x HDMI 1.4 (3840 x 2160 @30Hz) 1 x DP 1.4 (4096x2160@60Hz)
<b>Power Connector</b>	1 x 2 pin terminal block

## 1.4.4 Environment

<b>Operating Temperature*</b>	-20 ~ 60° C (-4 ~ 140° F) @5~85% RH with 0.7 m/s airflow
<b>Storage Temperature</b>	-40 ~ 85° C (-40 ~ 185° F)
<b>Relative Humidity</b>	10~95% RH @ 40° C/104° F, non-condensing
<b>Shock Protection</b>	Operating, IEC 60068-2-27, 50G, half sine, 11ms
<b>Vibration Protection</b>	Operating, IEC 60068-2-64, 2Grms, random, 5 ~500Hz, 1hr/axis (mSATA)
<b>Ingress Protection</b>	IP30

## 1.4.5 Certification

<b>Certification</b>	CE, FCC, UL, CCC, BSMI
----------------------	------------------------

## 1.4.6 Extension Kit (Optional)

UNO-2372G V2 features a modularized design. Advantech offers two optional 2nd stack extension kits for users to expand the functionality using an Advantech iDoor module.

<b>Part number</b>	UNO-2372G-EKCE
<b>Description</b>	2nd stack extension kit to support 2 x iDoor module w/ powder coat
<b>Ports</b>	1 x iDoor installation space
<b>Dimensions (W x D x H)</b>	35 x 105 x 150 mm (11.8 x 27.6 x39.3 in)
<b>Weight</b>	0.2 kg (0.44 lbs)

**Note!** Most of the iDoor modules can handle system operating temperatures of 60° C (140° F).









# Chapter 2

## Hardware Functionality

This chapter details setup instructions for UNO-2372G V2's hardware functions. It includes connecting peripherals and indicators.

- Introduction
- External I/O Connector
- Internal I/O Connector
- LED Indicators
- Reset Buttons
- Antenna Hole

## 2.1 Introduction

The following figures show the connectors on UNO-2372G V2. Information regarding each peripheral is provided in the following sections.

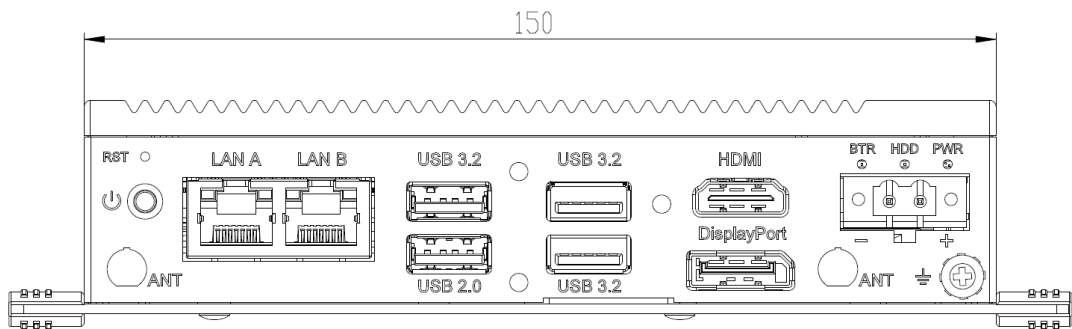

Figure 2.1 Front Panel of UNO-2372G V2

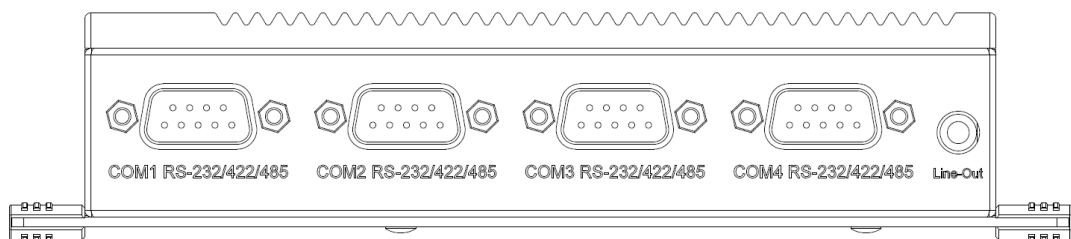

Figure 2.2 Rear Panel of UNO-2372G V2

## 2.2 Serial Communication Ports

The UNO-2372G V2 is equipped with four standard COM serial communication ports – COM1, COM2, COM3, and COM4. The port settings can be adjusted from the BIOS menu. Drivers are installed automatically during OS installation.

### 2.2.1 COM Port Interfaces (COM1, COM2, COM3, COM4)

The UNO-2372G V2 features four RS-232/422/485 ports (DB9, 50 ~ 115.2 kbps). The default setting for COM1 ~ 4 is RS-232. These settings can be adjusted in the BIOS menu. (Please refer to User Manual- Appendix A.8 for RS232/422/485 settings).

### 2.2.2 Power Connector

UNO-2372G V2 comes with a Phoenix connector that carries 10 - 36 V<sub>DC</sub> external power input, and features reversed wiring protection. Therefore, the system will not accrue damage from reversed polarity of ground lines and power lines. (Please refer to User Manual - Appendix A.1 for pin assignments)

### 2.2.3 LAN: Ethernet Connector

UNO-2372G V2 is equipped with two Gigabit LAN controllers. An Realtek® 8119i Ethernet controller that complies with IEEE 802.3u 10/100/1000 Base-T is used as the controller chip. The Ethernet port is a standard RJ-45 jack. Additionally, LED indicators are provided on the front of the device to indicate the system's Link (off/green/orange) and Active (green) status. (Please refer to User Manual- Appendix A.2 for pin assignments.)

## 2.2.4 USB Connector

UNO-2372G V2 features 3 x USB ports for Rev. 3.2 specifications and 1 x USB 2.0port. The USB connectors support plug-and-play and hot-swap-ping functionality for external devices. Additionally, this can be enabled/disabled in the BIOS menu. (Please refer to User Manual- Appendix A.3 for pin assignments.)

## 2.2.5 HDMI Connector

The UNO-2372G V2 provides 1 x HDMI 1.4connector for a high resolution interface, 3840 x 2160 @30Hz. (Please refer to User Manual- Appendix A.4 for pin assignments.

## 2.2.6 DP Connector

The UNO-2372G V2 provides 1 x DP 1.4 connector for a high resolution interface, 4096x2160@60Hz. (Please refer to User Manual- Appendix A.4 for pin assignments.)

## 2.2.7 RTC Battery

The UNO-2372G is equipped with an RTC battery to ensure that the system clock and BIOS settings are retained after power disconnections.

- **Type:** BR2032
- **Output Voltage:** 3 V<sub>DC</sub>

## 2.2.8 Power Button/Power Management

Press the “PWR” button to power on/off the UNO-2372G V2 (ATX type). The system can be configured to AT mode by adjusting the onboard switch to automatically turn the system on when there is power input. (Refer to Appendix A.2 for more information.)

## 2.2.9 Reset Button

Press the “Reset” button to activate the hardware reset function.

## 2.2.10 mPCIe Connector

The UNO-2372G V2 supports 1x mPCI Express mini card sockets. The MINIPCIE1 interface is provided to support various mPCIe extension modules for diverse applications. The UNO-2372G V2 double-stack model also supports the integration of iDoor modules (e.g., DI/O, COM, industrial fieldbus, etc.) via the MINI1 interface.

## 2.2.11 M.2 B-key Connector

There is one M.2 B Key connector for M.2 cards, labeled “M2\_B1” on the mother board. This M.2 interface is USB3.0 signal. It supports the installation of M.2 2242 or 3042/3052 module (w/ USB 3.0 Signal).

(Please refer to user manual Appendix A.5 for pin assignments.)

**Note!** *In addition to the M.2 B key (M2\_B1) socket, the system features a micro SIM slot for supporting 5G/LTE function. However, users are required to install a 5G/LTE M.2 B key module to enable this function.*



## 2.2.12 M.2 M-key Connector

There is one M.2 M Key connector for M.2 cards, labeled “M2\_M1” on the mother board. This M.2 M key interface is a PCIeX2/ SATA signal. it supports the installation of M.2 2242 storage module.

## 2.2.13 Nano SIM Slot

There's one Nano SIM slot for supporting LTE function, labeled “CN10” on board. In addition to install SIM card on “CN10”, users are required to install a LTE Module on “M2\_B1” M.2 B Key to enable the functionality.

## 2.2.14 LED Indicators

Three LEDs indicate the status of the system's power and RTC battery.

- PWR (Power): Green indicates “normal” and orange indicates “standby”.

This product offers two antenna mounting holes covered by pre-cut holes for users to install an antenna kit for LTE or wireless functions.

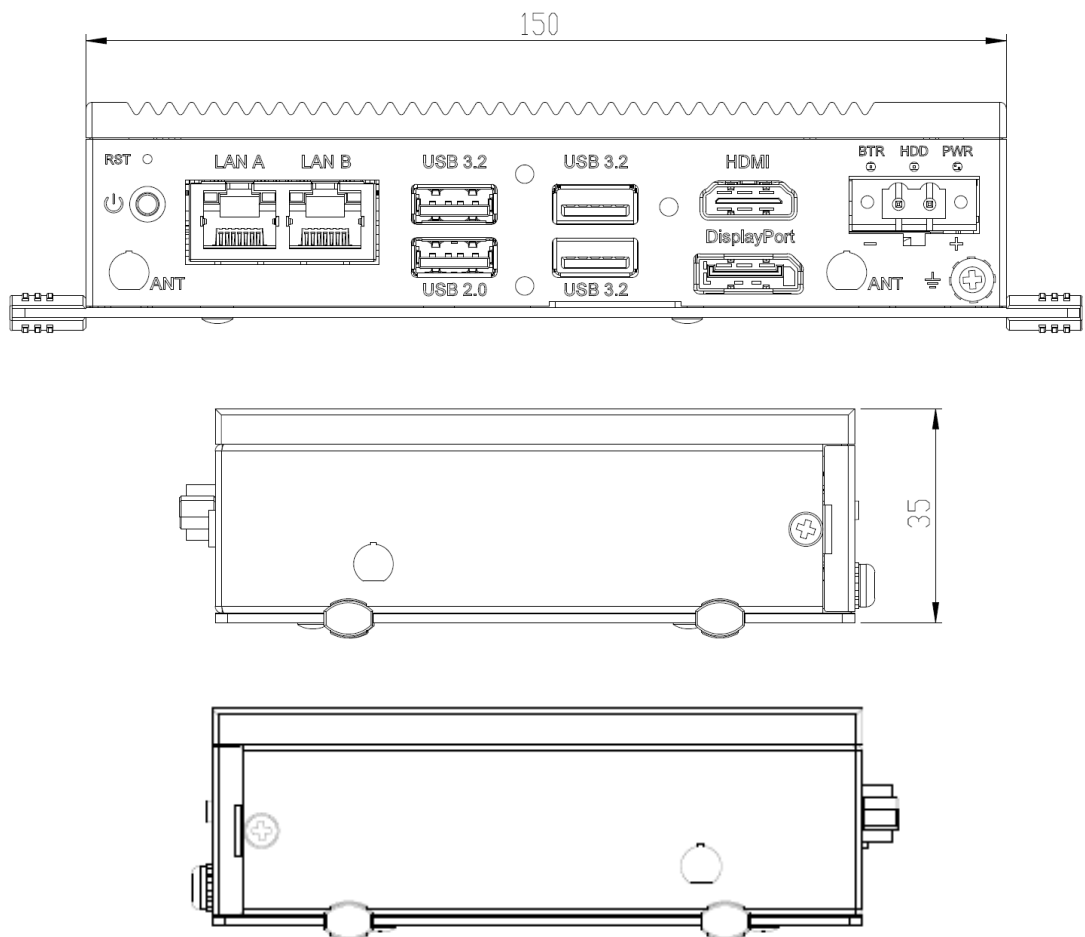
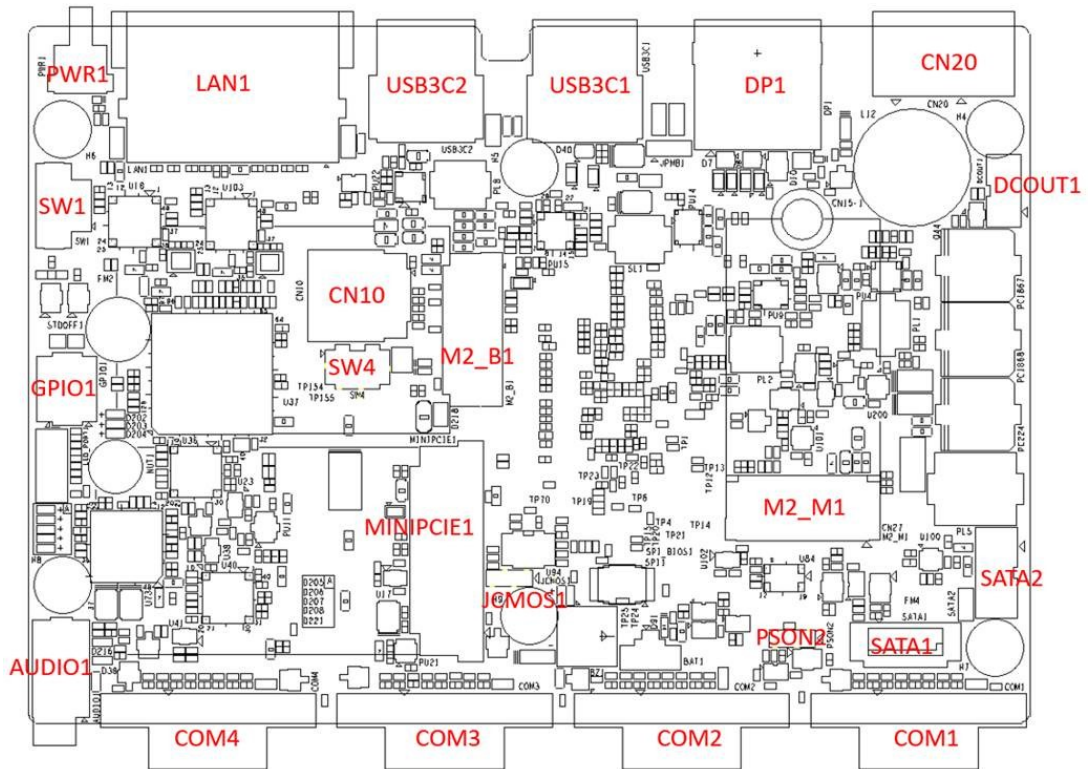

Figure 2.3 LED Indicators, Reset Buttons, and Antenna Hole

**Note!** Please be aware of the maximum OD value of the antenna hole when selecting antenna.



## 2.3 Base Unit's Internal Connectors



**Figure 2.4 Diagram of Connector Locations on UNO-2372G V2 (Top Side)**

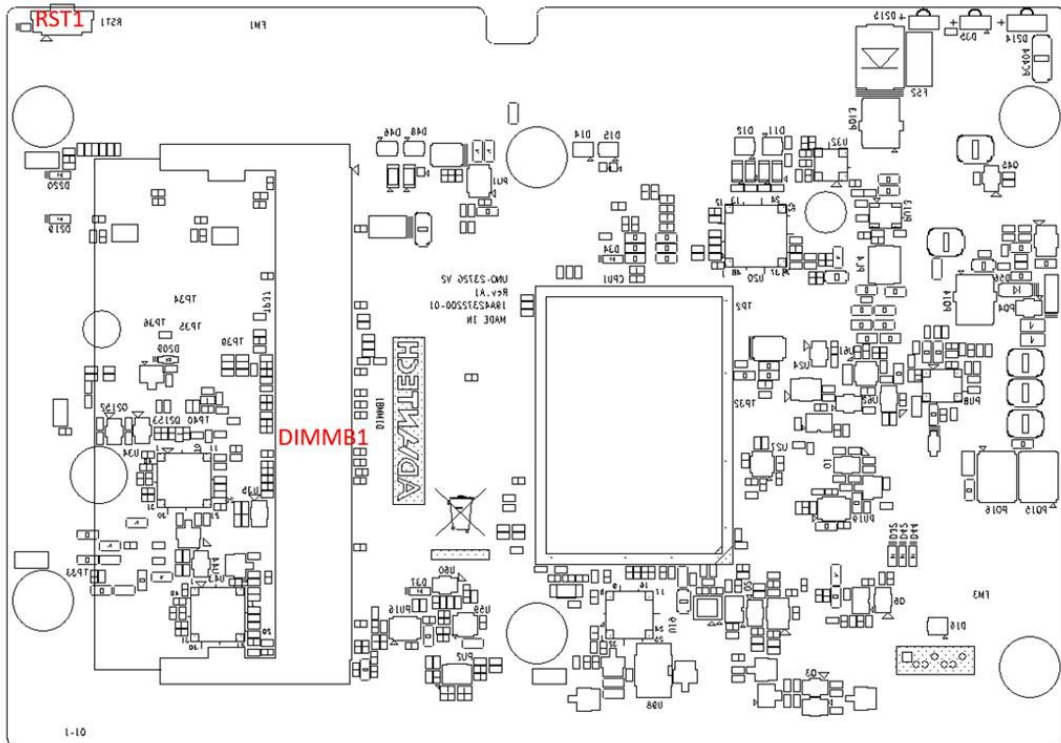

**Figure 2.5 Diagram of Key Components Location on UNO-2372G V2 (Bottom Side)**

**Table 2.1: Key Components, Connectors on Mother Board**

Category	Label	Function
External	PWR1	Power button
	RST1	Reset button
	DP1	HDMI/DP connector
	LAN1	LAN connector
	USB3C1/USB3C2	USB 3.0 connector
	DCIN1	DC input connector
	COM1/2/3/4	COM port (COM1/2/3/4), BIOS setting RS-232/RS-422/RS-485
Internal	JCMOS1	Clear CMOS Function
	PSON2	Power AT/ATX
	MINIPCIE1	MPCIE SLOT
	M2_B1	M.2 B-Key (M2_B1) for LTE (3042)/5G(3052) module (USB signal)
	M2_M1	M.2 M-Key for NVMe (2242) PCIe x2/B+M (2242) SATA
	SW4	M.2 B-key GPIO pull up level
	CN10	Nano SIM slot for M2_B1
	SW1	Remote Power/Reset button



# Chapter 3

## Initial Setup

This chapter explains how to initialize the UNO-2372G V2.

- Chassis Grounding
- Connecting Power
- Open and Close Bottom Cover
- Installing a 2nd Stack Extension Kit
- Installing internal component
- Antenna Installation (Optional)
- BIOS Settings

## 3.1 Chassis Grounding

The UNO-2372G V2 provides good EMI protection and a stable grounding base and there is an easy-to-connect chassis grounding point for this purpose.

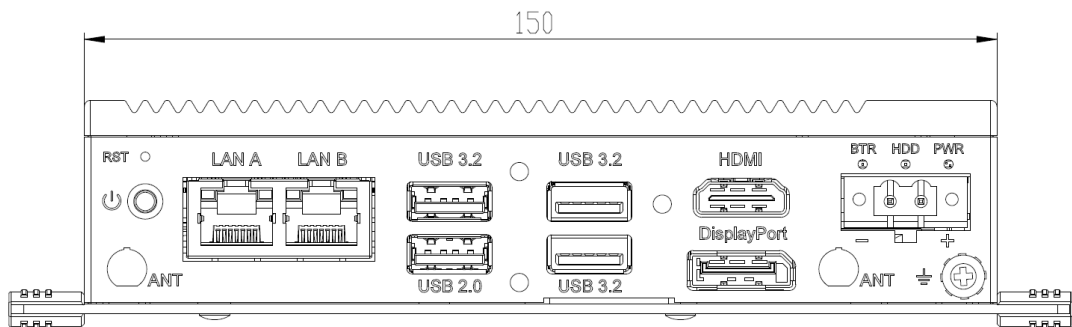

Figure 3.1 Chassis Grounding Connection Diagram

Use the grounding cable (16 AWG) from the accessory bag to connect the chassis ground with the Earth ground.

## 3.2 Connecting Power

This product is intended to be supplied by an approved power adapter or DC power source. This adapter is rated at 10 - 36dc, 1.5-5.4A and has a T<sub>max</sub> of 60° C (140° F). If you need further assistance or information, please contact Advantech.

**Note!** It is recommended to choose a 60W adapter when selected iDoor expansion module (e.g. PCM-24R2PE) is installed. Recommended PN: 96PSA-A120W19T2-3.



Follow the following instructions:

1. Insert the positive and negative wires into the V+ and V- contacts on the terminal block connector.
2. Tighten the wire-clamp screws to prevent the DC wires from coming loose.

Take the following guidelines into consideration before wiring the device:

1. The terminal block is suitable for 14-24 AWG (8A). The torque value is 7.0 lb-in, pitch 5.08mm. Use copper conductors only.
2. The temperature rating of the input connection cable should be higher than 105° C (221° F).

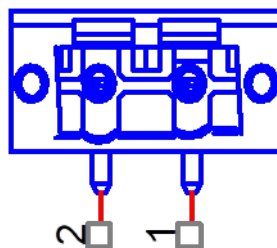

### 3.3 Open and Close Bottom Cover

The steps for opening and closing the bottom cover of UNO-2372G V2 are demonstrated below.

1. To open the bottom cover: Remove the 4 rubber feet first, then remove 2 screws from the back cover.

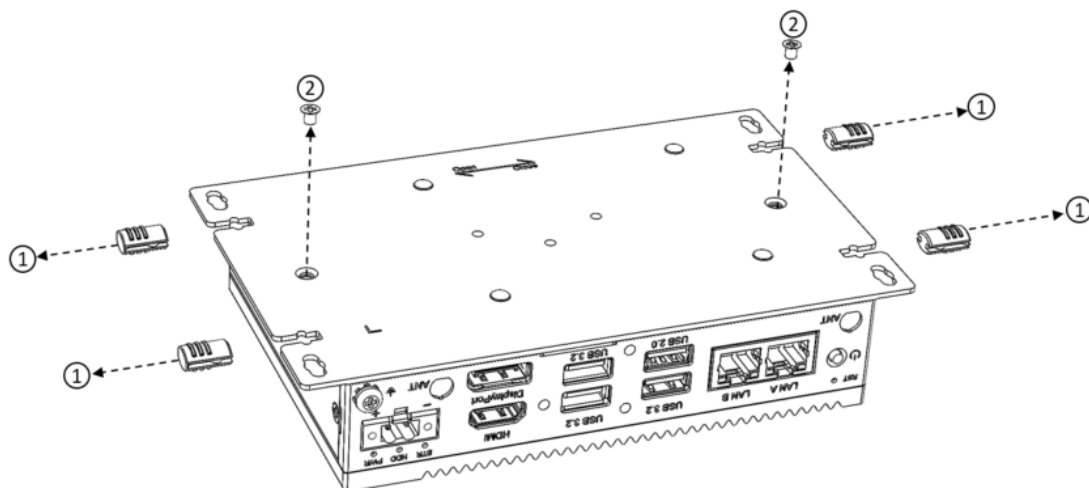

2. To move the bottom cover as the "open" direction and lift it up.

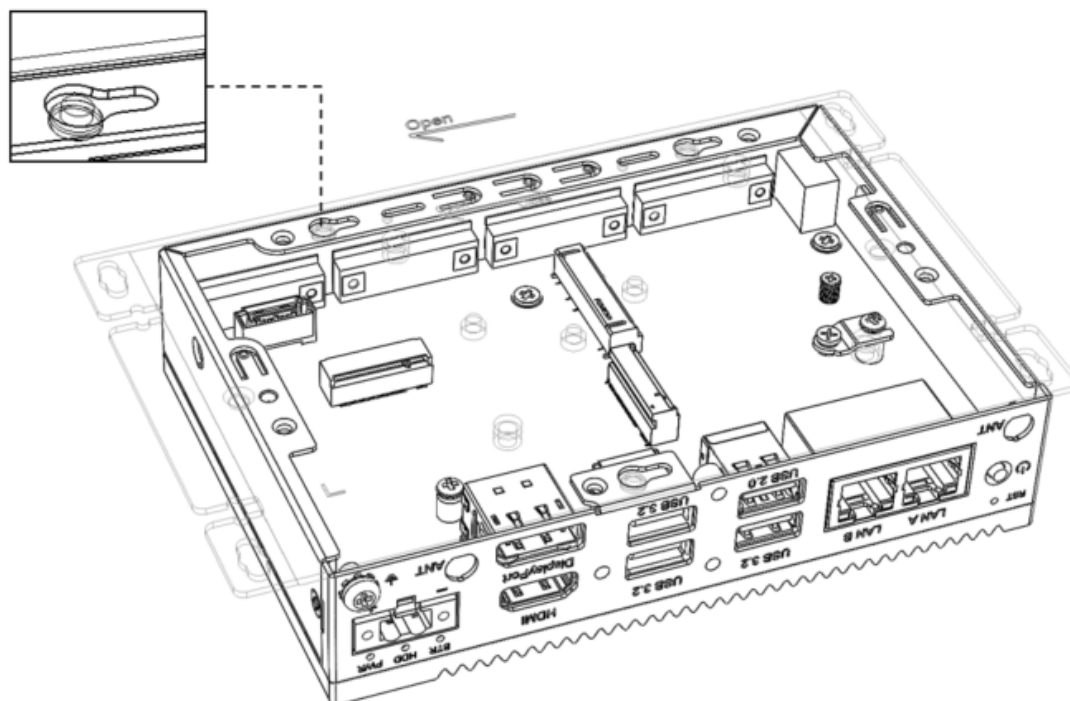

3. To close the bottom cover: To put the back cover on the system, and move the snap on the "close" direction.

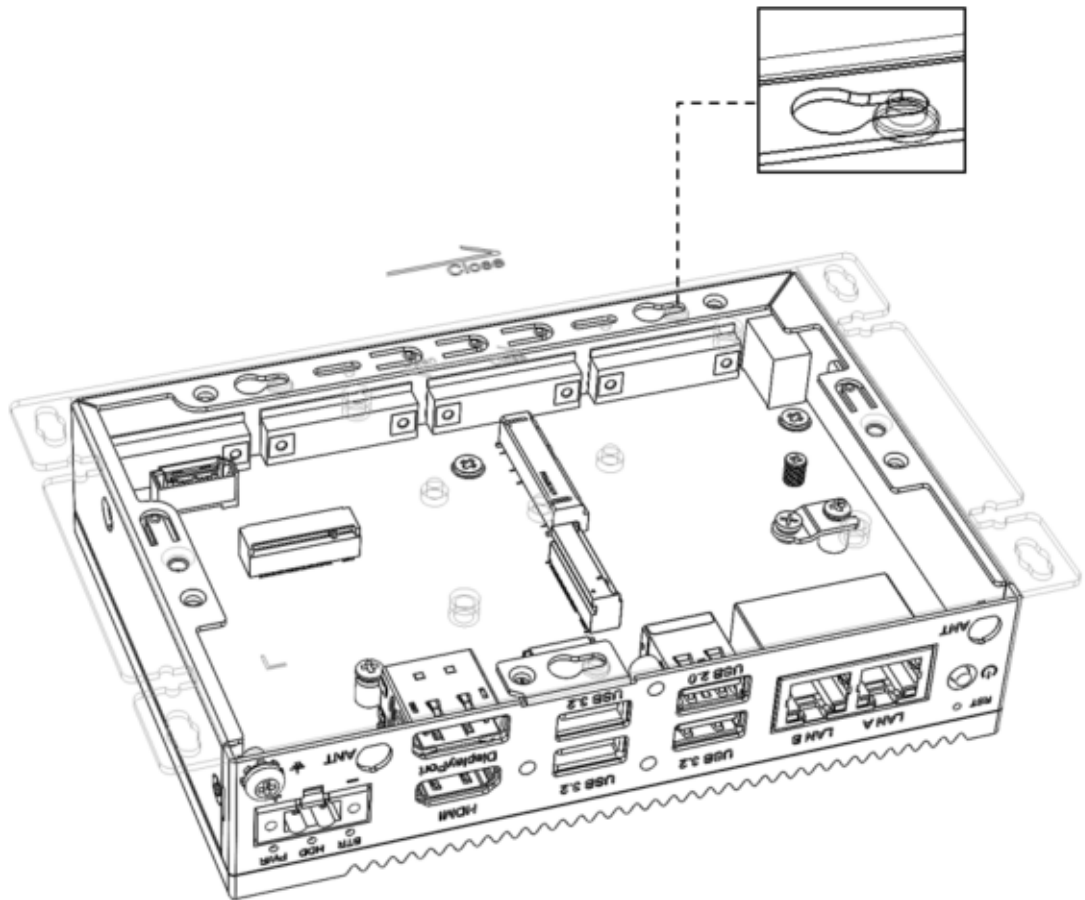

4. To close the bottom cover: lock the 2 screws and add the 4 rubber feet back.

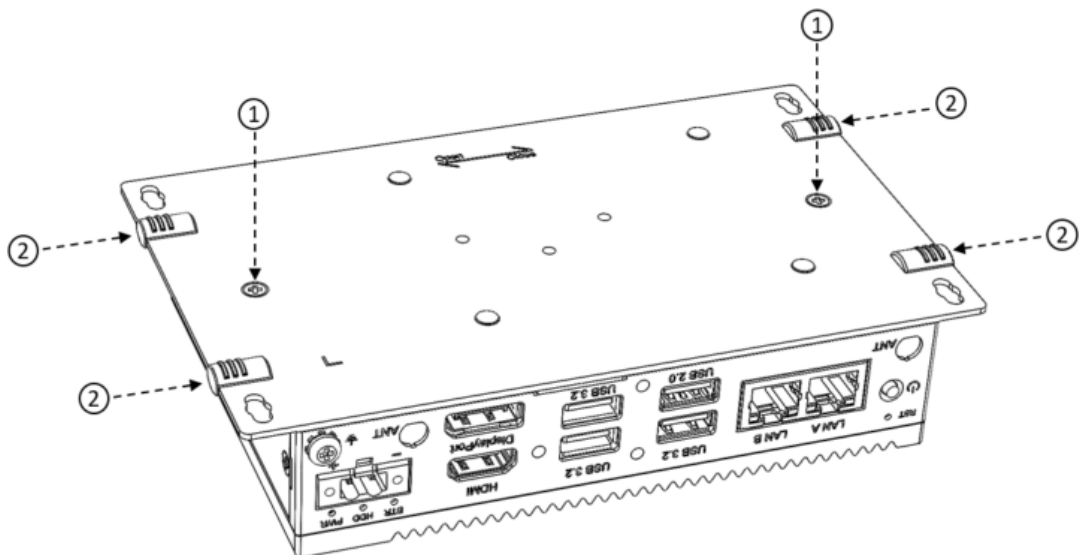

### 3.4 Installing 2.5" HDD/SSD (height is within 7mm)

1. Lift the back cover and remove the 4 buttons.

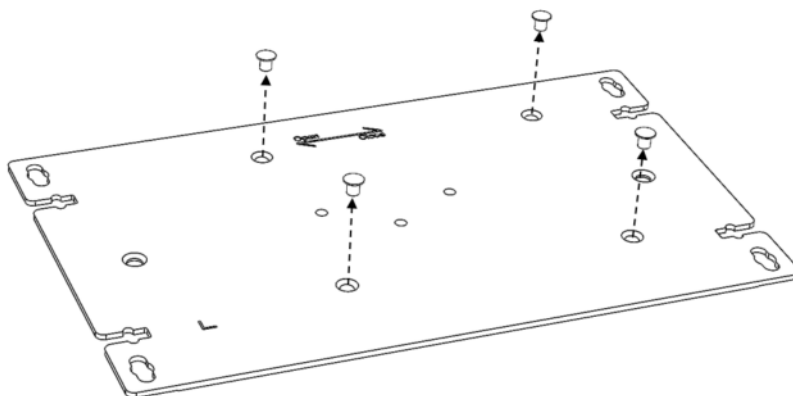

2. Lock the HDD bracket with 4 screws on the back cover.

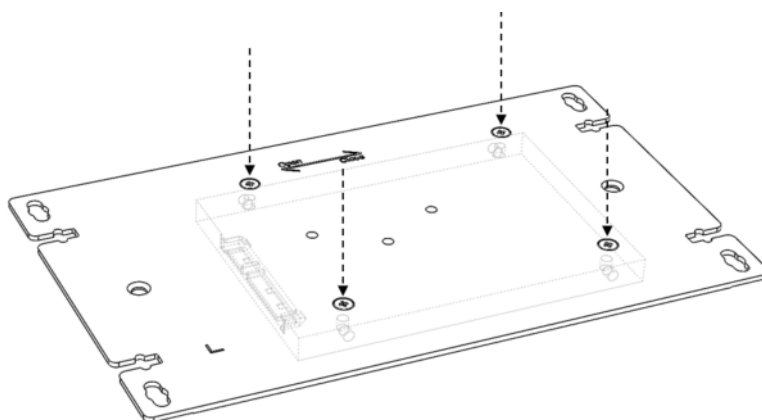

3. Insert the SATA cable and lock 2 screws on the back cover.

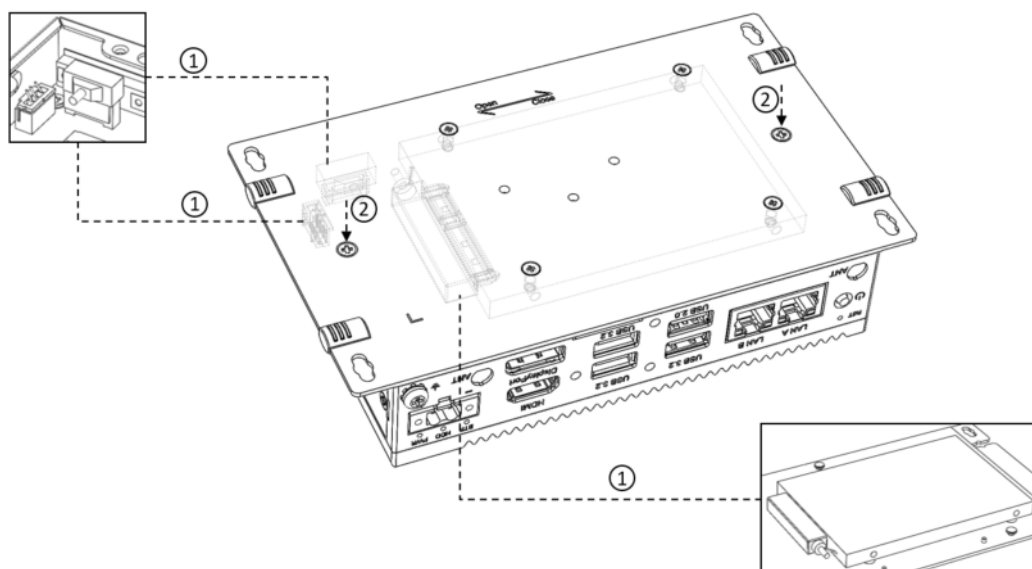

### 3.5 Installing 2.5" HDD/SSD (height is within 7mm) on 2nd stack

1. Lock 4 screws on HDD/ SSD, then lock 4 screws on the HDD bracket on 2nd stack, and insert the SATA cable.

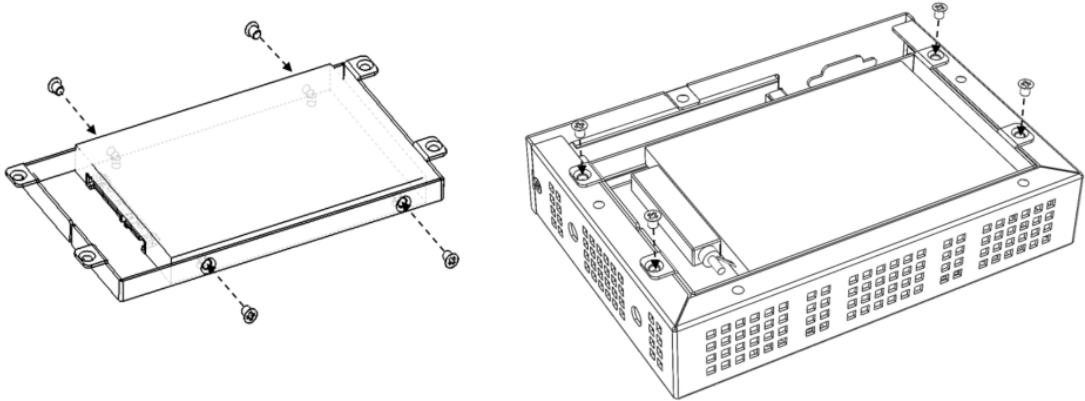

2. Lock the 2nd stack on the base unit with 5 screws.

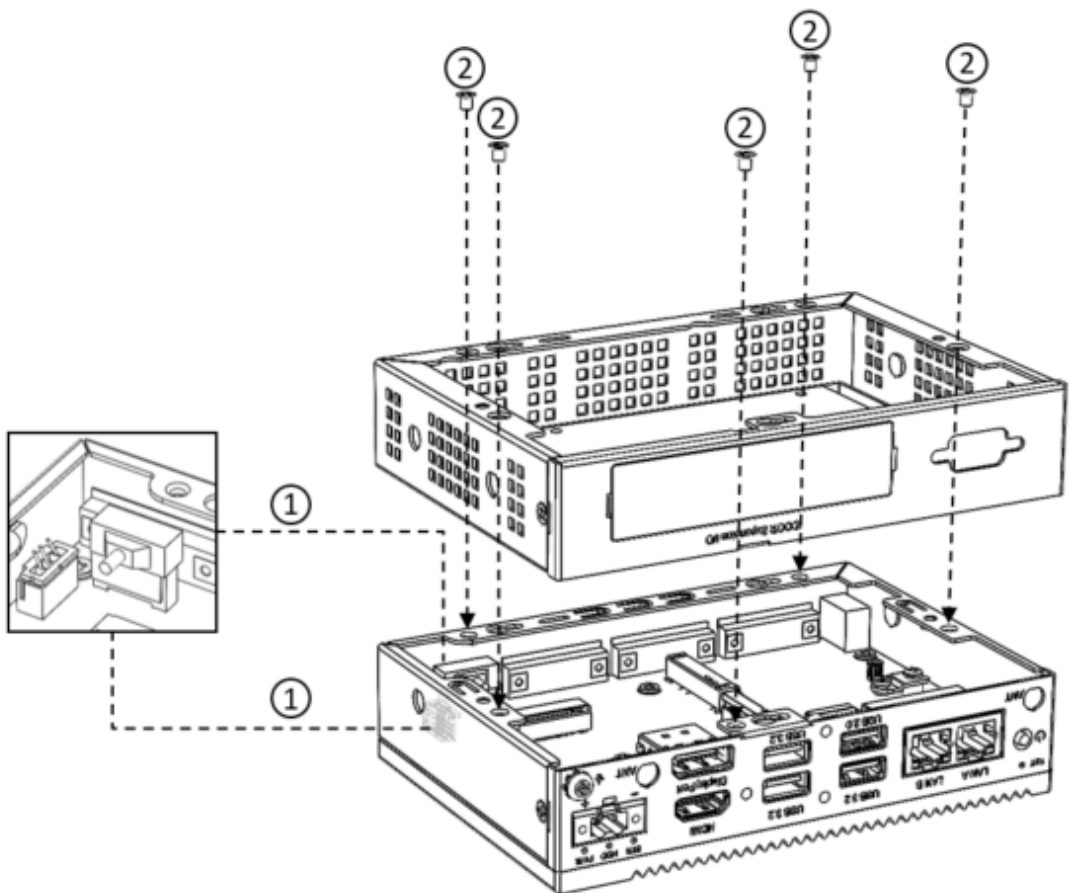

- Put the back cover on the system, and move the snap on the “close” direction, then lock the 2 screws and add the 4 rubber feet back.

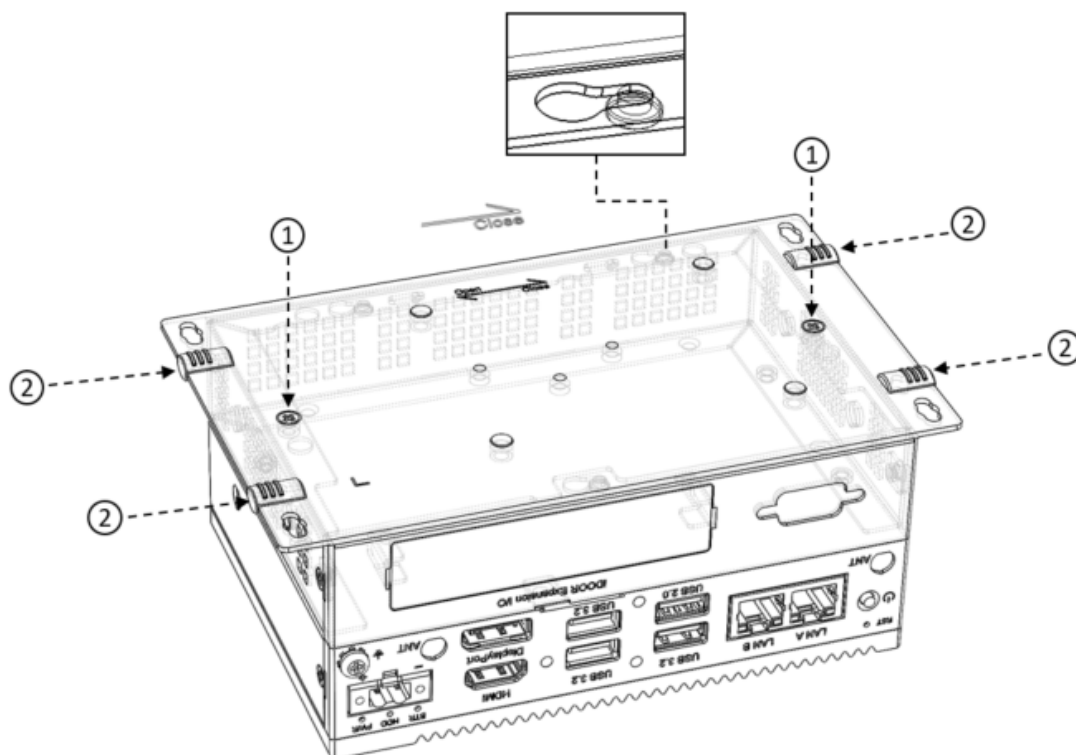

## 3.6 Installing Internal Component

### 3.6.1 Installing M.2 2242 Card

Remove the back cover and the pre-installed screw, insert the 2242 card and replace the screws.

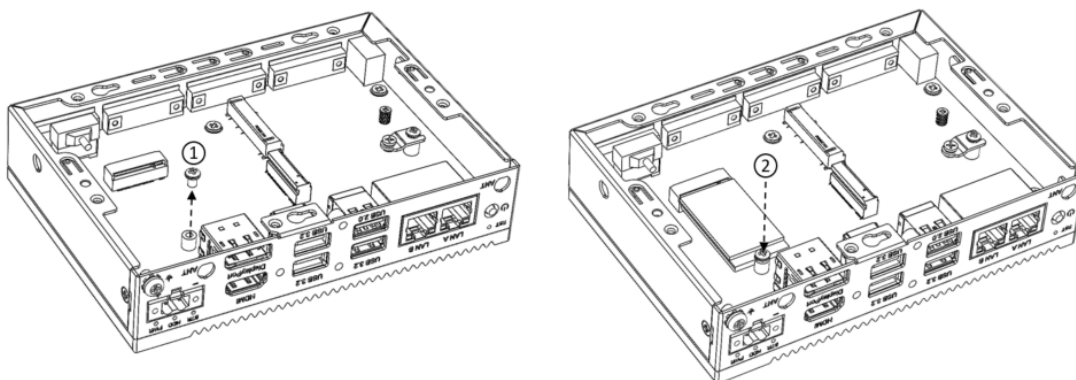

### 3.6.2 Installing M.2 M key 3042 Card

Remove the back cover and the pre-installed screw, insert the 3042 card and replace the screws.

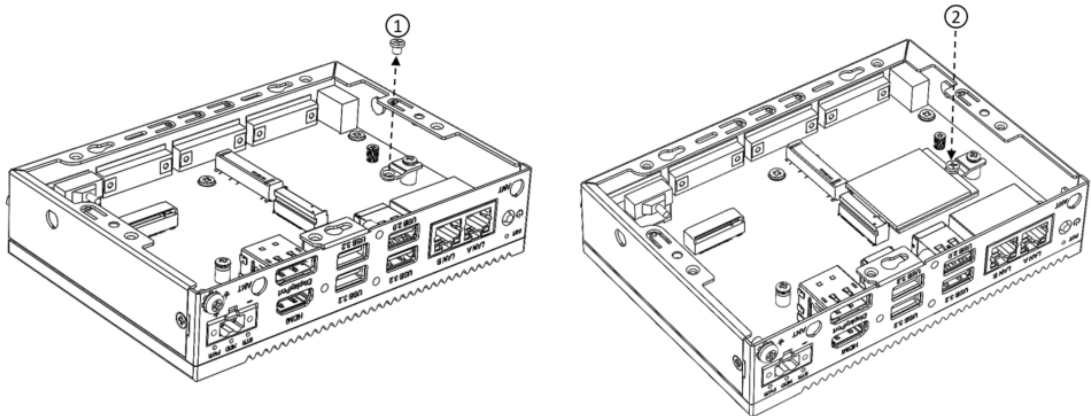

### 3.6.3 Installing M.2 B Key 3042 Card

Remove the back cover and the pre-installed screw, insert the 3042 card and replace the screws.

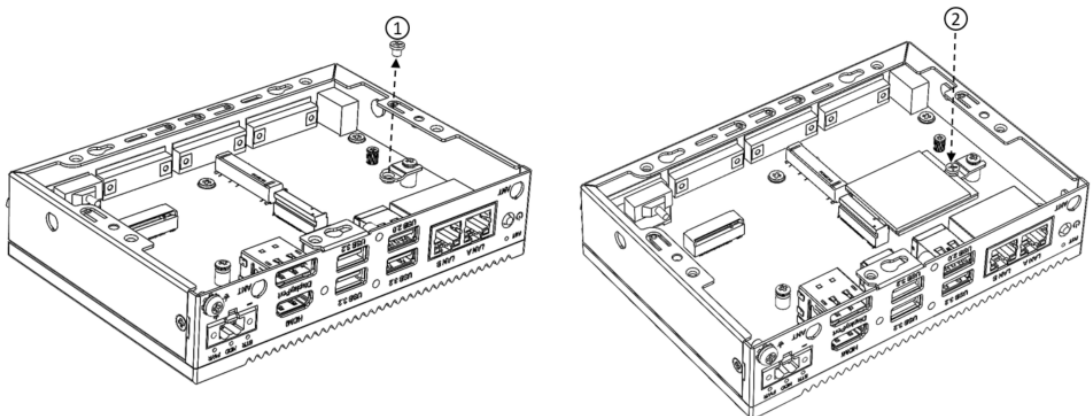

### 3.6.4 Installing M.2 B Key 3052 Card

Remove the back cover, the pre-installed screw and the converter bracket, insert the 3052 card and replace the screws.

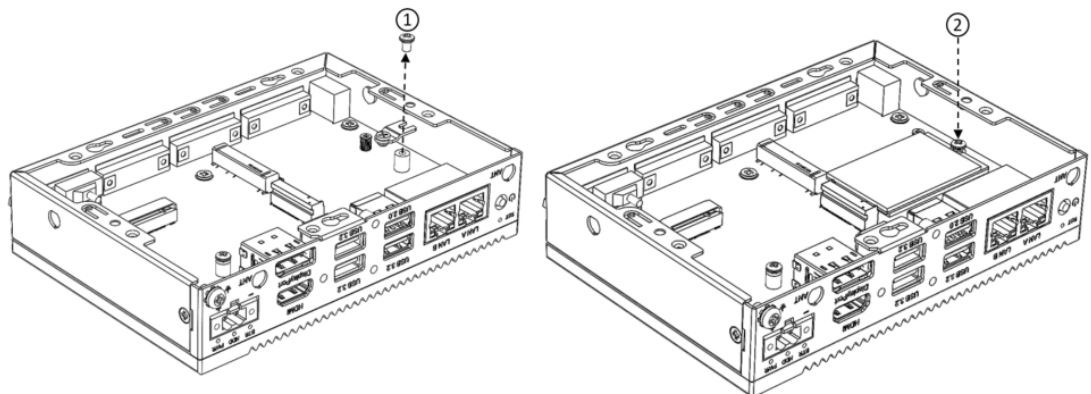



### 3.6.5 Installing the mPCIE Module

Remove the back cover and the pre-installed screw, insert the mPCIE card and replace the screws.

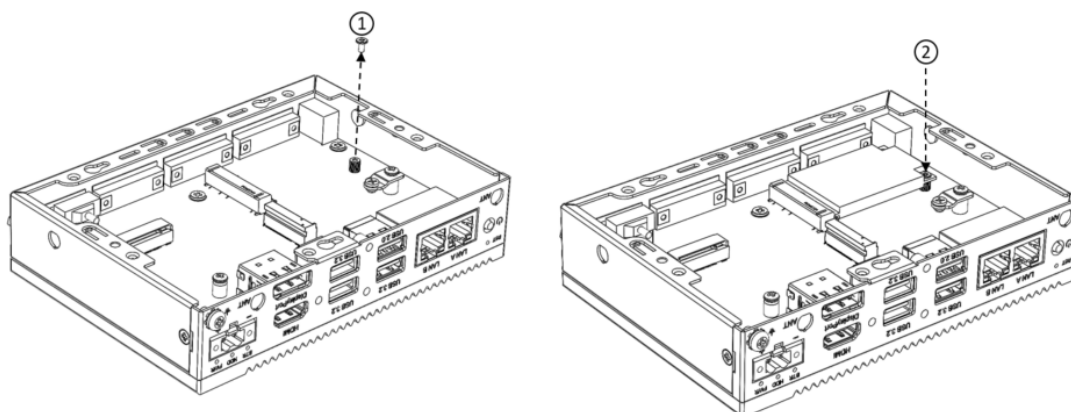

## 3.7 Antenna Installation (Optional)

UNO-2372G V2 reserves pre-cut antenna hole for wireless connection. Follow the steps below for installation the SMA cable and antenna.

1. Remove the back cover and the plug of the antenna's pre-cutting hole. assemble the gasket and the nuts.

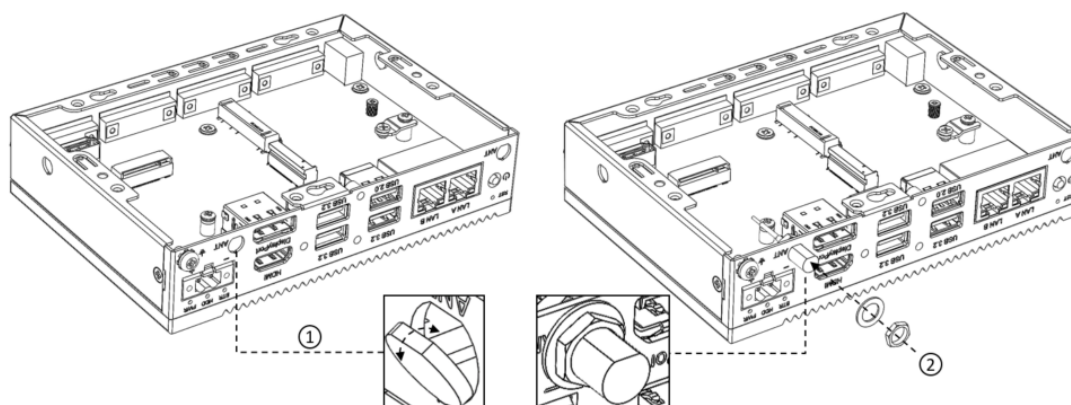

2. Assemble Antenna on the pre-cut hole.

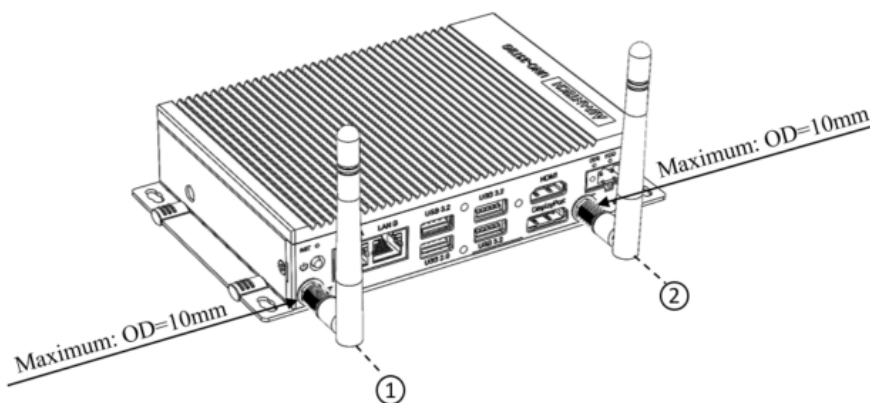

Base unit with 2 antenna

Remind: When the UNO-2372G V2 base unit assemble 4pcs antenna, it can not bundle with 2.5 inch SSD/HDD.

The 2.5 inch SSD/HDD can be assembled on the double stack SKU with 4pcs antenna.

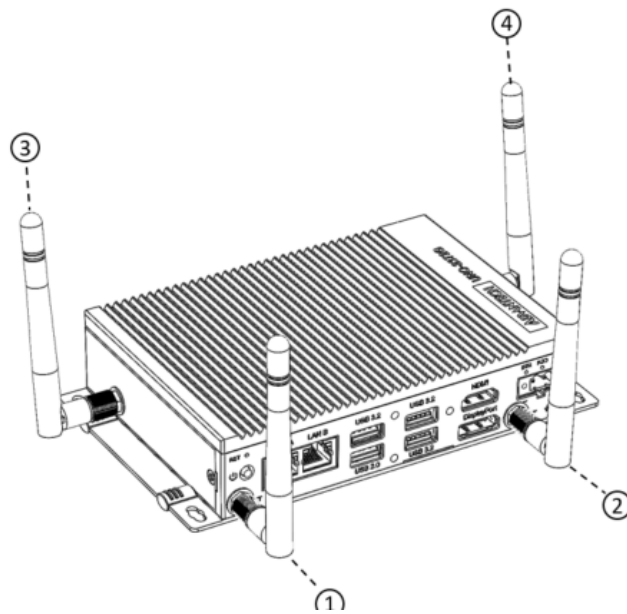

Base unit with 4 antenna

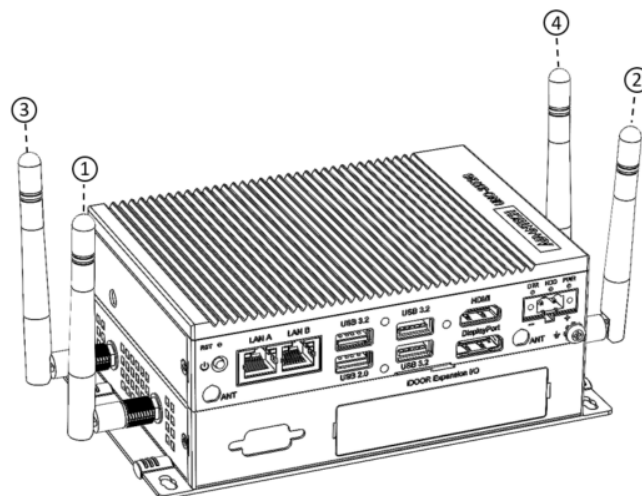

Double stack with 4 antenna

### 3.8 BIOS Setting

With the BIOS Setup program, you can modify BIOS settings and control the special features of your computer. The Setup program uses a number of menus for making changes and turning special features on or off.

Press the “ESC” key upon the first boot up to enter the BIOS setup screen, after then, press the “Del” key during the Power On Self Test (POST) process to enter the BIOS setup screen, otherwise the system will continue the POST process. (Please refer to User Manual- Appendix A.10-A.12

# Appendix **A**

System Settings/Pin  
Assignments

## A.1 Power Connector (DCIN1)

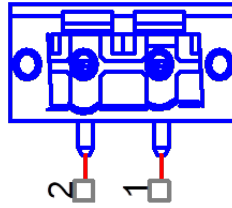

**Table A.1: Power Connector Pin Assignments**

Pin	Signal	Description
1	Power IN V+	10 - 36 V <sub>DC</sub>
2	Power IN V- (GND)	

## A.2 LAN: Ethernet Connector (LAN1)

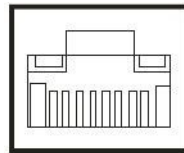

**Table A.2: Ethernet Connector Pin Assignments**

RJ45 Pin	Signal	Description
1	MDI0+	<ul style="list-style-type: none"> <li>■ In BASE-T: Media Dependent Interface[0]:</li> <li>■ 1000BASE-T: In MDI configuration, MDI[0]+/- corresponds to BI_DA+/- and in MDI-X configuration MDI[0]+/- corresponds to BI_DB+/-.</li> <li>■ 10BASE-T and 100BASE-TX: In MDI configuration, MDI[0]+/- is used for the transmit pair and in MDIX configuration MDI[0]+/- is used for the receive pair.</li> </ul>
2	MDI0-	
3	MDI1+	<ul style="list-style-type: none"> <li>■ In BASE-T: Media Dependent Interface[1]:</li> <li>■ 1000BASE-T: In MDI configuration, MDI[1]+/- corresponds to BI_DB+/- and in MDI-X configuration MDI[1]+/- corresponds to BI_DA+/-.</li> <li>■ 10BASE-T and 100BASE-TX: In MDI configuration MDI[1]+/- is used for the receive pair and in MDI-X configuration MDI[1]+/- is used for the transmit pair.</li> </ul>
6	MDI1-	
4	MDI2+	<ul style="list-style-type: none"> <li>■ In BASE-T: Media Dependent Interface[3:2]:</li> <li>■ 1000BASE-T: In MDI and in MDI-X configuration, MDI[2]+/- corresponds to BI_DC+/- and MDI[3]+/- corresponds to BI_DD+/-.</li> <li>■ 100BASE-TX: Unused.</li> <li>■ 10BASE-T: Unused.</li> </ul>
5	MDI2-	
7	MDI3+	
8	MDI3-	

Left LED		Right LED	
10 Link	100 Link	1000 Link	Active
Off	Orange	Green	Green

## A.3 USB Connector (USB3C1/USB3C2)

### A.3.1 USB 3.0 Connector

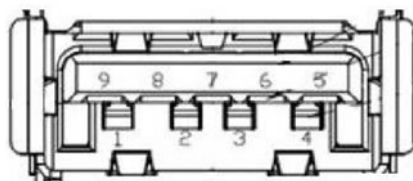
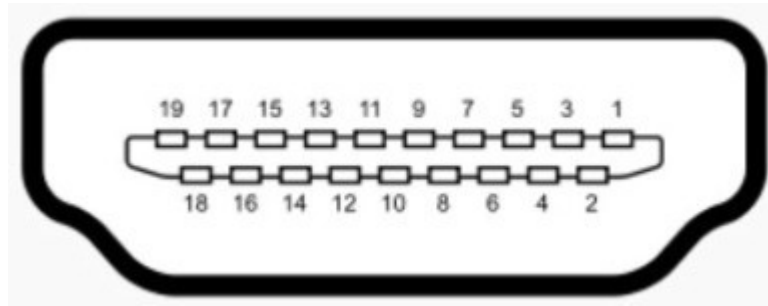

Table A.3: USB 3.0 Connector Pin Assignments		
Pin	Signal Name	Description
1	VBUS	Power
2	D-	USB 2.0 differential pair
3	D+	
4	GND	Ground for power return
5	StdA_SSRX-	SuperSpeed receiver differential pair
6	StdA_SSRX+	
7	GND_DRIAN	Ground for signal return
8	StdA_SSTX-	SuperSpeed transmitter differential pair
9	StdA_SSTX+	

## A.4 HDMI Connector (DP1)



**Table A.4: Display Port Adapter Cable Pin Assignments**

Pin	Signal Name
1	TMDS1_a_P0
2	GND
3	TMDS1_a_N0
4	TMDS1_a_P1
5	GND
6	TMDS1_a_N1
7	TMDS1_a_P2
8	GND
9	TMDS1_a_N2
10	TMDS1_CLK_a_P
11	GND
12	TMDS1_CLK_a_N
13	NC
14	NC
15	TMDS1_DDCCLK
16	TMDS1_DDCDAT
17	GND
18	+V5
19	TMDS1_HPD

## A.5 M.2 B-key Connector (M2\_B1)

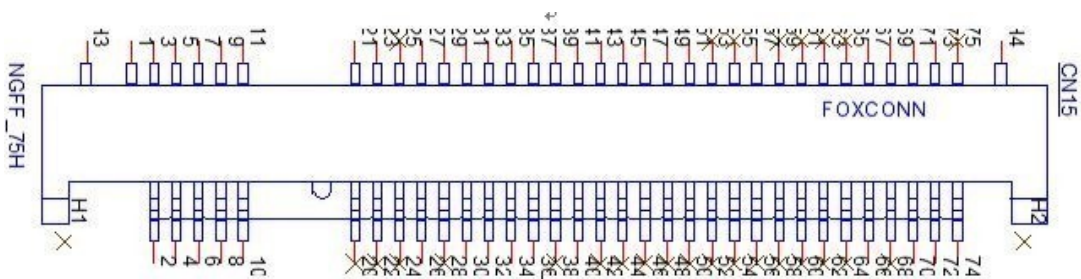
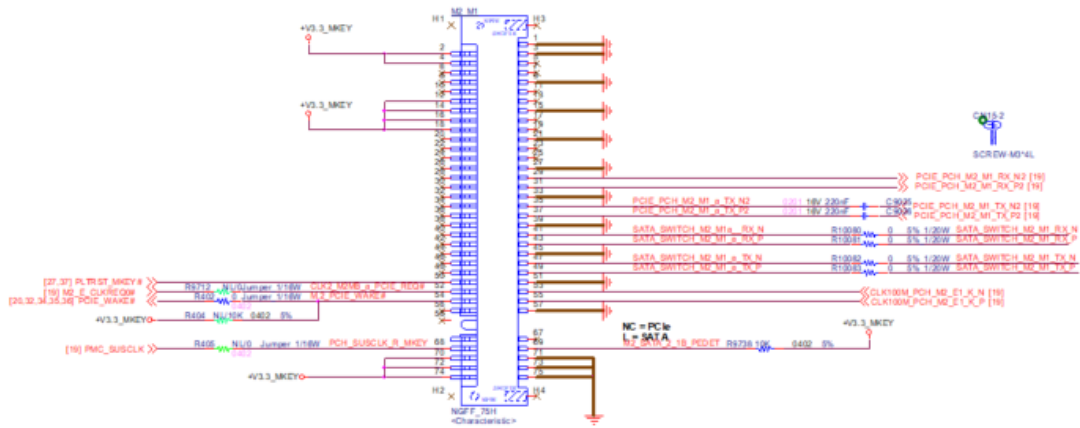

Table A.5: M.2 B Key Connector Pin Assignments			
Pin	Signal Name	Pin	Signal Name
1	M2_SATA1_DET	2	+V3.3_M2
3	GND	4	+V3.3_M2
5	GND	6	M2_LTE_PWR_OFF#
7	M2_LTE_USB_DP	8	M2_LTE_W1_DISABLE_N
9	M2_LTE_USB_DN	10	+V3.3_M2
11	GND	12	Mechanical notch B
13	Mechanical notch B	14	Mechanical notch B
15	Mechanical notch B	16	Mechanical notch B
17	Mechanical notch B	18	Mechanical notch B
19	Mechanical notch B	20	NC
21	NC	22	NC
23	WAKE_ON_WAN#	24	NC
25	NC	26	M2_LTE_W2_DISABLE_N
27	GND	28	NC
29	USB_Z_SSRX1-	30	M2_SIM1_RESET
31	USB_Z_SSRX1+	32	M2_SIM1_CLK
33	GND	34	M2_SIM1_DATA
35	USB_C_SSTX1-	36	M2_SIM1_PWR
37	USB_C_SSTX1+	38	NC
39	GND	40	M2_SIM2_DET
41	SATA1_RX+	42	NC
43	SATA1_RX-	44	NC
45	GND	46	NC
47	SATA1_C_TX-	48	NC
49	SATA1_C_TX+	50	NC
51	GND	52	NC
53	NC	54	NC

**Table A.5: M.2 B Key Connector Pin Assignments**

55	NC	56	NC
57	GND	58	NC
59	NC	60	NC
61	NC	62	NC
63	NC	64	NC
65	NC	66	M2_SIM1_DET
67	LTE_RST#_P67	68	NC
69	NC	70	+V3.3_M2
71	GND	72	+V3.3_M2
73	GND	74	+V3.3_M2
75	NC		

## A.6 M.2 M-Key Connector (M2\_M1)



**Table A.6: M.2 M key Connector Pin Assignments**

Pin	Signal Name	Pin	Signal Name
1	GND	2	+V3.3_MKEY
3	GND	4	+V3.3_MKEY
5	NC	6	M2E_LED_1#
7	NC	8	NC
9	GND	10	NC
11	NC	12	+V3.3_MKEY
13	NC	14	+V3.3_MKEY
15	GND	16	+V3.3_MKEY
17	NC	18	+V3.3_MKEY
19	NC	20	+V3.3_MKEY
21	GND	22	NC



Table A.6: M.2 M key Connector Pin Assignments			
23	NC	24	
25	NC	26	
27	GND	28	
29	PCIE_PCH_M2_M1_RX_N2	30	
31	PCIE_PCH_M2_M1_RX_P2	32	NC
33	GND	34	NC
35	PCIE_PCH_M2_M1_TX_N2	36	NC
37	PCIE_PCH_M2_M1_TX_P2	38	NC
39	GND	40	NC
41	SATA_SWITCH_M2_M1_RX_N	42	NC
43	SATA_SWITCH_M2_M1_RX_P	44	NC
45	GND	46	NC
47	SATA_SWITCH_M2_M1_TX_N	48	NC
49	SATA_SWITCH_M2_M1_TX_P	50	PLTRST_MKEY#
51	GND	52	M2_E_CLKREQ0#
53	CLK100M_PCH_M2_E1_K_N	54	PCIE_WAKE#
55	CLK100M_PCH_M2_E1_K_P	56	NC
57	GND	58	NC
59	Mechanical notch E	60	Mechanical notch E
61	Mechanical notch E	62	Mechanical notch E
63	Mechanical notch E	64	Mechanical notch E
65	Mechanical notch E	66	Mechanical notch E
67	NC	68	PMC_SUSCLK
69	M2_SATA_2_1B_PEDET	70	+V3.3_MKEY
71	GND	72	+V3.3_MKEY
73	GND	74	+V3.3_MKEY
75	GND		

## A.7 mPCIe Connector (MINIPCI E1)

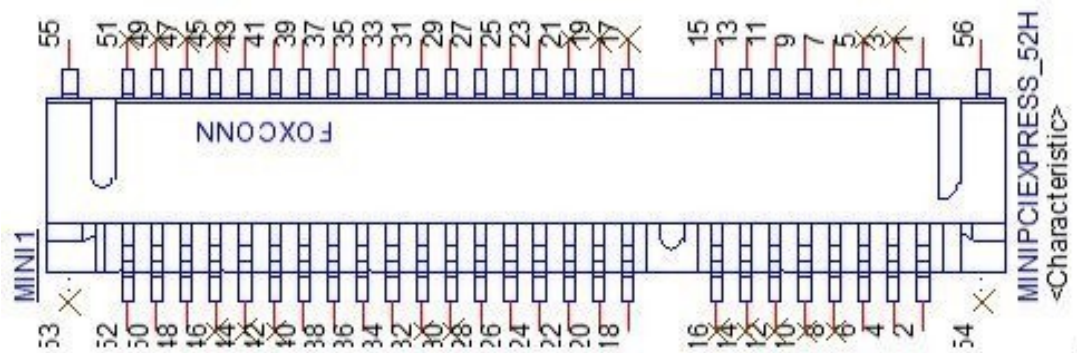
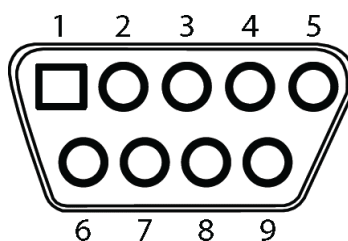

**Table A.7: mPCIe Connector Pin Assignments**

Pin	Signal Name	Pin	Signal Name
1	PCIE_WAKE#	2	+V3.3_MINI
3	NC	4	GND
5	NC	6	+V1.5
7	PCIEX1_CLKREQ0#	8	NC
9	GND	10	NC
11	CLK100M_PCIEX1_D0-	12	NC
13	CLK100M_PCIEX1_D0+	14	NC
15	GND	16	NC
17	NC	18	GND
19	NC	20	WIFI_DISABLE#
21	NC	22	MINI_PLTRST#
23	SATA0_RX+	24	+V3.3_MINI
25	SATA0_RX-	26	GND
27	GND	28	+V1.5
29	GND	30	NC
31	SATA0_TX-	32	NC
33	SATA0_TX+	34	GND
35	GND	36	USB2_MPCI_P8-
37	GND	38	USB2_MPCI_P8+
39	+V3.3_MINI	40	GND
41	+V3.3_MINI	42	NC
43	MPCI_PWRSEL	44	NC
45	NC	46	NC
47	NC	48	+V1.5
49	NC	50	GND
51	MSATA#_z_PCIE_SEL	52	+V3.3_MINI

## A.8 COM Port RS232/422/485 Settings

Pin	RS232	RS422	RS485
1	DCD	TX-	D-
2	RX	TX+	D+
3	TX	RX+	
4	DTR	RX-	
5	GND	GND	GND
6	DSR		
7	RTS		
8	CTS		
9	RI		



## A.9 AT/ATX Setting (PSON2)

PSON1 can be used for AT/ATX setting. The default setting is ATX mode. See the following table for jumper configuration

AT	1-2	
ATX	2-3	Default



## A.10 SW1

SW1 for remote Power/Reset button setting. Pin define of SW1 is listed below:

Pin Define	
Pin	Signal Name
1	Power button
2	GND
3	GND
4	Reset button

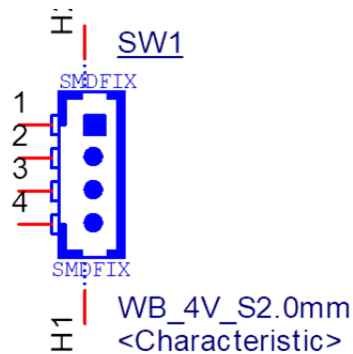

## A.11 JCMOS Clear Function

The JCMOS jumper is used to select CMOS clear Enable or Disable.

CMOS CLR Jumper	
Mode	Jumper Setting
Normal (default)	1-2
CLR COMS	2-3

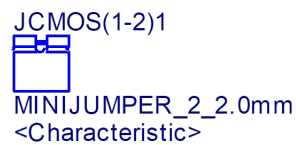
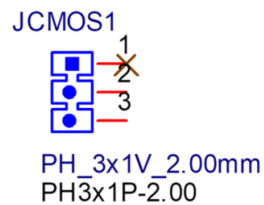

## A.12 TPM 2.0 BIOS Setting

The UNO-2372G V2 systems support TPM 2.0 functionality. This can be enabled or disabled in the BIOS menu by following the instructions provided below:

1. Power on the UNO-2372G V2 system and press “Delete” to enter the BIOS configuration menu.
2. On the “Advanced” tab, select the “Trusted Computing” item.

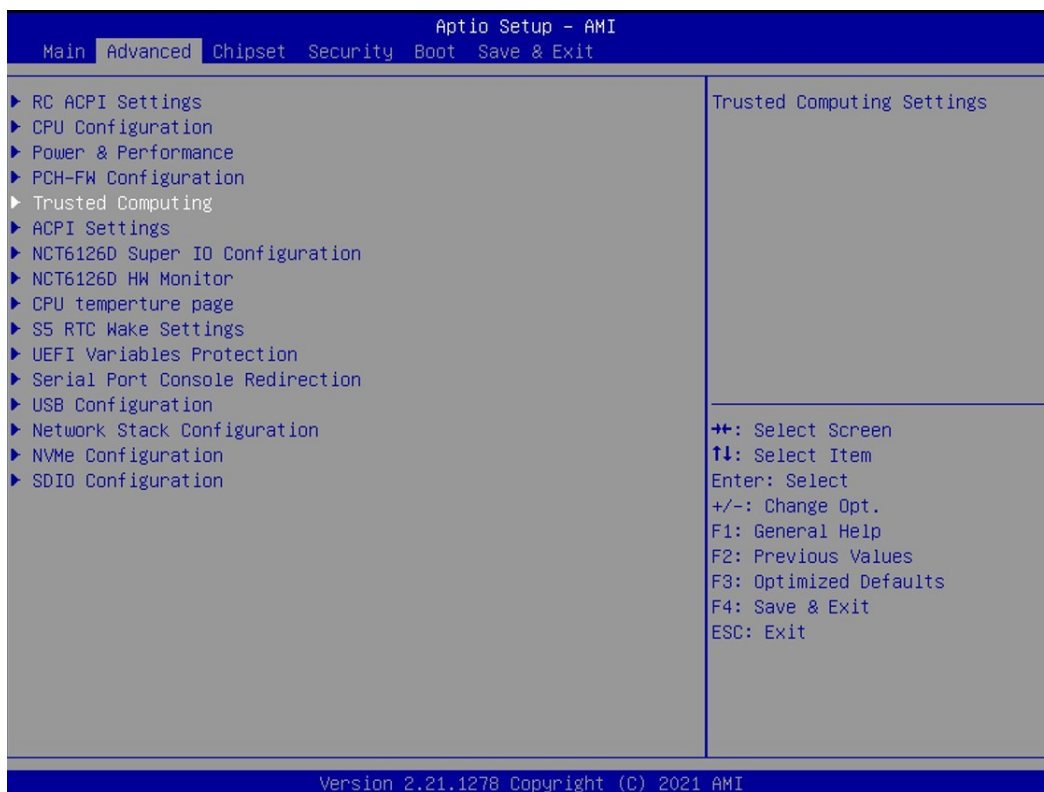

3. Then select the “Security Device Support” item.
4. Choose “enable/disable” to enable or disable the TPM 2.0 function (The default setting is to disable this function).

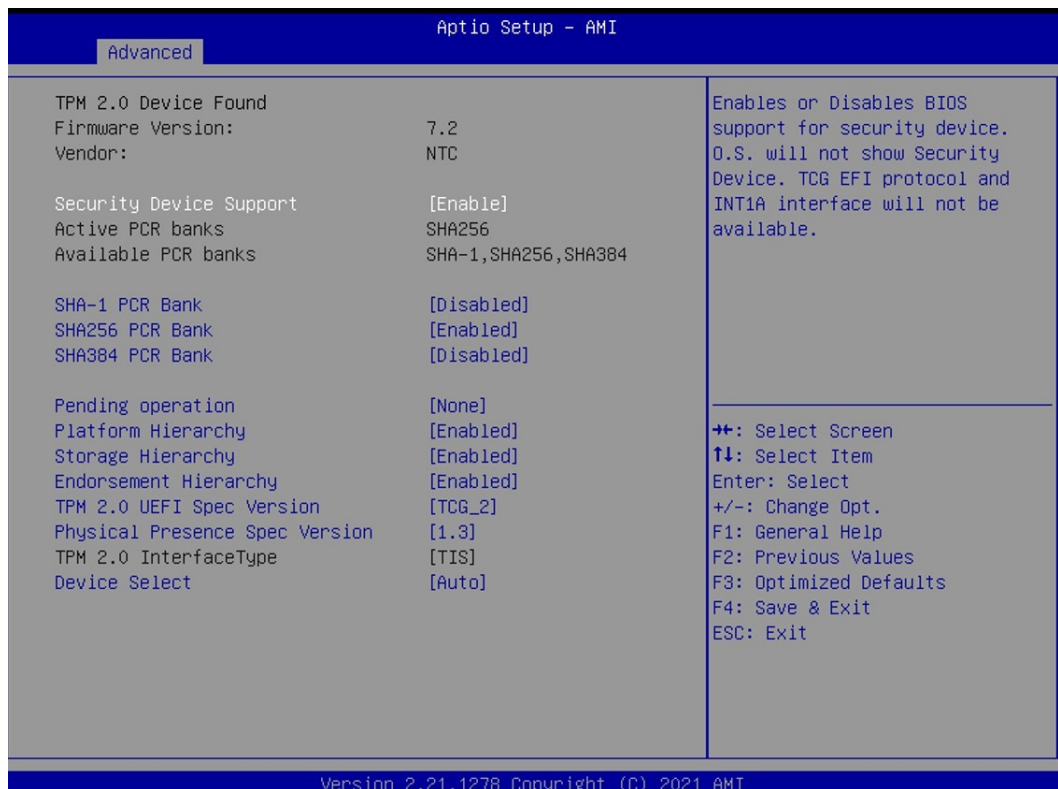

## A.13 CPU Turbo Mode BIOS Setting

The UNO-2372G V2 systems supports CPU Turbo mode. This can be enabled or disabled in the BIOS menu by following the instructions:

1. Power on the UNO-2372G V2 system and press “Delete” to enter the BIOS configuration menu.
2. On the “Advanced” tab, select the “Power & Performance” item.
3. Then select the “Turbo Mode” item.
4. Choose “enable/disable” to enable or disable the Turbo mode.



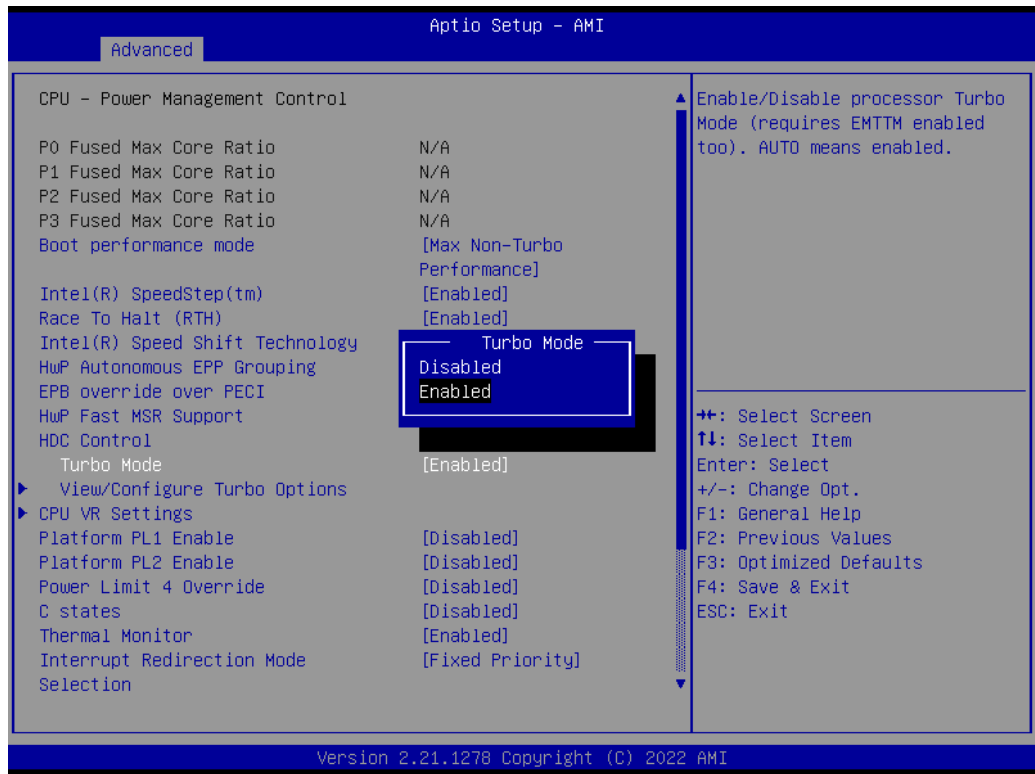
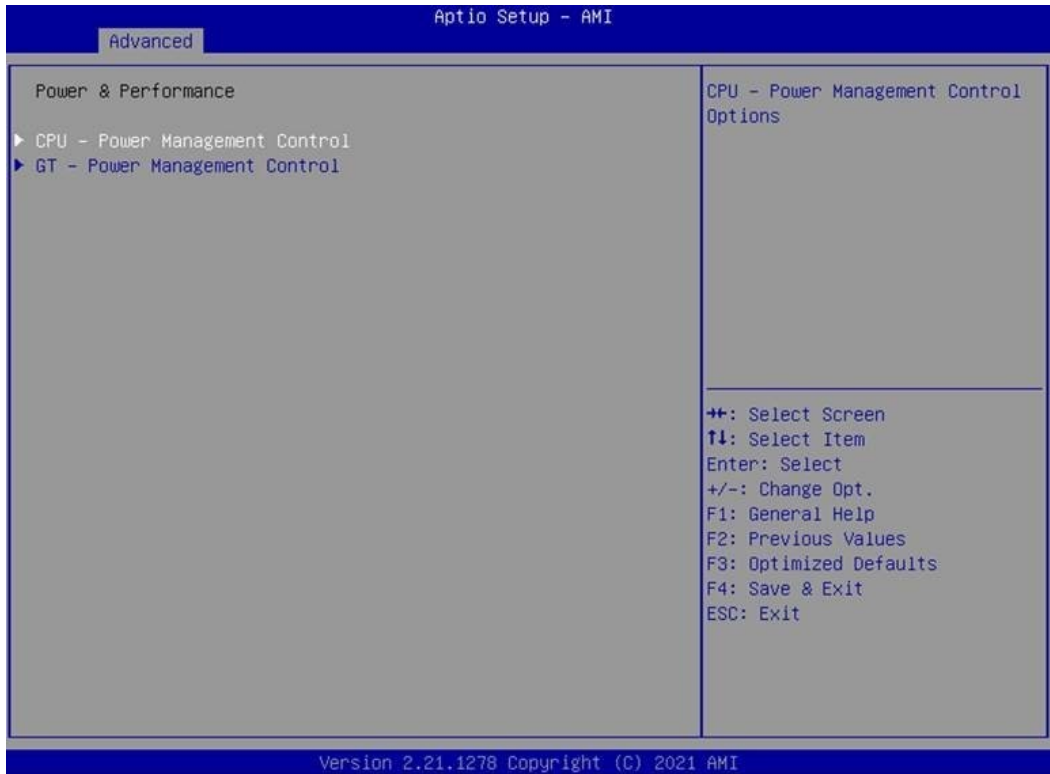





## [www.advantech.com](http://www.advantech.com)

Please verify specifications before quoting. This guide is intended for reference purposes only.

All product specifications are subject to change without notice.

No part of this publication may be reproduced in any form or by any means, such as electronically, by photocopying, recording, or otherwise, without prior written permission from the publisher.

All brand and product names are trademarks or registered trademarks of their respective companies.

© Advantech Co., Ltd. 2022