

# SCM5B40/41



## Analog Voltage Input Modules, Wide Bandwidth

### Description

Each SCM5B40 and SCM5B41 wide bandwidth voltage input module provides a single channel of analog input which is amplified, isolated, and converted to a high level analog voltage output (Figure 1). This voltage output is logic-switch controlled, allowing these modules to share a common analog bus without the requirement of external multiplexers.

The SCM5B modules are designed with a completely isolated computer side circuit which can be floated to  $\pm 50V$  from Power Common, pin 16. This complete isolation means that no connection is required between I/O Common and Power Common for proper operation of the output switch. If desired, the output switch can be turned on continuously by simply connecting pin 22, the Read-Enable pin, to I/O Common, pin 19.

The input signal is processed through a pre-amplifier on the field side of the isolation barrier. This pre-amplifier has a gain-bandwidth product of 5MHz and is bandwidth limited to 10kHz. After amplification, the input signal is chopped by a proprietary chopper circuit. Isolation is provided by transformer coupling, again using a proprietary technique to suppress transmission of common mode spikes or surges. The module is powered from +5VDC,  $\pm 5\%$ .

A special input circuit on the SCM5B40 and SCM5B41 modules provides protection against accidental connection of power-line voltages up to 240VAC.

### ► Features

- Accepts Millivolt and Voltage Level Signals
- High Level Voltage Outputs
- 1500Vrms Transformer Isolation
- ANSI/IEEE C37.90.1 Transient Protection
- Input Protected to 240VAC Continuous
- 100dB CMR
- 10kHz Signal Bandwidth
- $\pm 0.03\%$  Accuracy
- $\pm 0.01\%$  Linearity
- $\pm 1\mu V/^\circ C$  Drift
- CSA Certified, FM Approved, CE and ATEX Compliant
- Mix and Match SCM5B Types on Backpanel

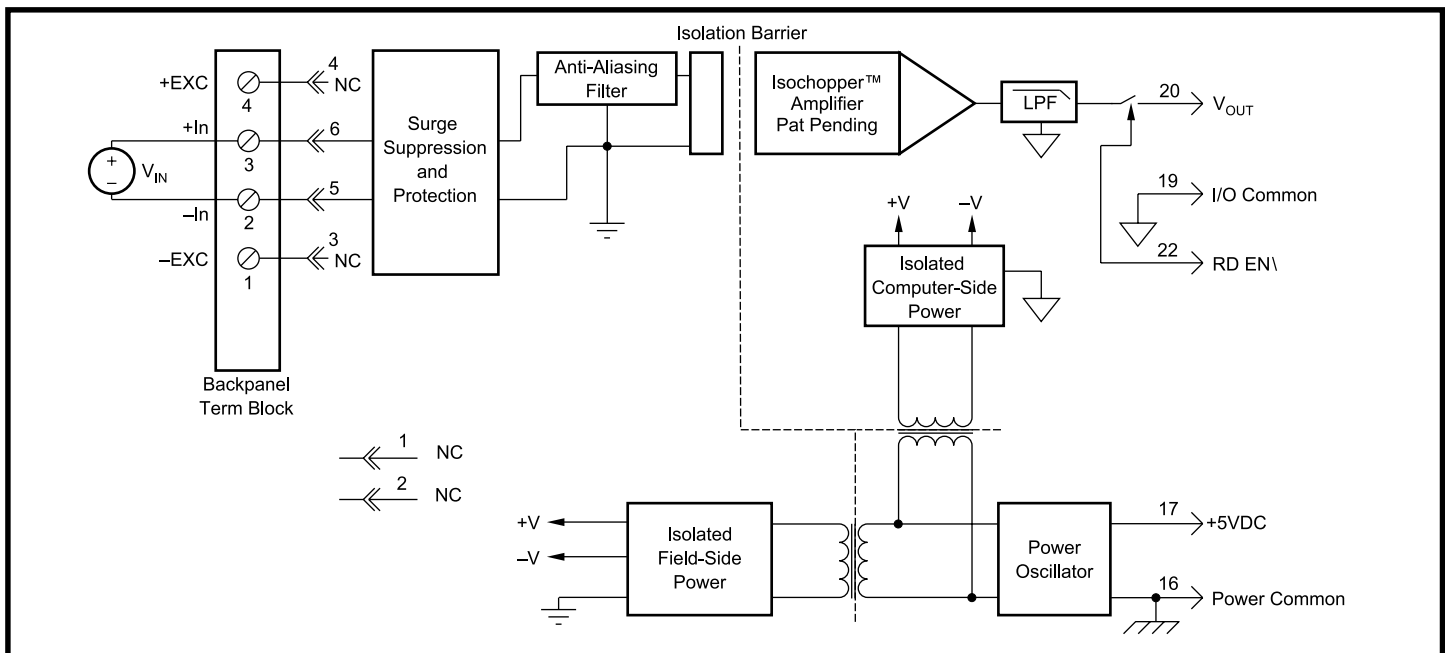

Figure 1: SCM5B40/41 Block Diagram

**Specifications** Typical at  $T_A = +25^\circ\text{C}$  and +5V power

Module	SCM5B40	SCM5B41
Input Range	$\pm 10\text{mV}$ to $\pm 100\text{mV}$	$\pm 1\text{V}$ to $\pm 40\text{V}$
Input Bias Current	$\pm 0.5\text{nA}$	$\pm 0.05\text{nA}$
Input Resistance		
Normal	200M $\Omega$	650k $\Omega$ (minimum)
Power Off	40k $\Omega$	650k $\Omega$ (minimum)
Overload	40k $\Omega$	650k $\Omega$ (minimum)
Input Protection		
Continuous	240Vrms max	*
Transient	ANSI/IEEE C37.90.1	*
CMV, Input to Output		
Continuous	1500Vrms max	*
Transient	ANSI/IEEE C37.90.1	*
CMR (50Hz or 60Hz)	100dB	*
NMR (-3dB at 10kHz)	120dB per Decade above 10kHz	*
Accuracy <sup>(1)</sup>	$\pm 0.03\%$ Span	*
Nonlinearity	$\pm 0.01\%$ Span	*
Stability		
Input Offset	$\pm 1\mu\text{V}/^\circ\text{C}$	$\pm 20\mu\text{V}/^\circ\text{C}$
Output Offset	$\pm 40\mu\text{V}/^\circ\text{C}$	*
Gain	$\pm 25\text{ppm}/^\circ\text{C}$	$\pm 50\text{ppm}/^\circ\text{C}$
Noise		
Input, 0.1 to 10Hz	0.4 $\mu\text{Vrms}$	2 $\mu\text{Vrms}$
Output, 100kHz	10mVp-p	*
Bandwidth, -3dB	10kHz	*
Rise Time, 10 to 90% Span	35 $\mu\text{s}$	*
Settling Time, to 0.1%	250 $\mu\text{s}$	*
Output Range	See Ordering Information	*
Output Resistance	50 $\Omega$	*
Output Protection	Continuous Short to Ground	*
Output Selection Time (to $\pm 1\text{mV}$ of $V_{\text{OUT}}$ )	6 $\mu\text{s}$ at $C_{\text{load}} = 0$ to 2000pF	*
Output Current Limit	$\pm 8\text{mA}$	*
Output Enable Control		
Max Logic "0"	+0.8V	*
Min Logic "1"	+2.4V	*
Max Logic "1"	+36V	*
Input Current "0,1"	0.5 $\mu\text{A}$	*
Power Supply Voltage	+5VDC $\pm 5\%$	*
Power Supply Current	30mA	*
Power Supply Sensitivity	$\pm 2\mu\text{V}/\%$ RTI <sup>(2)</sup>	$\pm 200\mu\text{V}/\%$ RTI <sup>(2)</sup>
Mechanical Dimensions (h)(w)(d)	2.28" x 2.26" x 0.60" (58mm x 57mm x 15mm)	*
Environmental		
Operating Temp. Range	-40 $^\circ\text{C}$ to +85 $^\circ\text{C}$	*
ATEX Group II, Cat. 3	-20 $^\circ\text{C}$ to +40 $^\circ\text{C}$	*
Storage Temp. Range	-40 $^\circ\text{C}$ to +85 $^\circ\text{C}$	*
Relative Humidity	0 to 95% Noncondensing	*
Emissions EN61000-6-4	ISM, Group 1	*
Radiated, Conducted	Class A	*
Immunity EN61000-6-2	ISM, Group 1	*
RF	Performance A $\pm 0.5\%$ Span Error	*
ESD,EFT, Surge, Voltage Dips	Performance B	*

## NOTES:

\* Same specification as SCM5B40.

(1) Includes nonlinearity, hysteresis and repeatability.

(2) RTI = Referenced to input.

 (3) Same as SCM5B41-01 with 50M $\Omega$  input resistance.

**Ordering Information**

Model	Input Range	Output Range <sup>†</sup>
SCM5B40-01	-10mV to +10mV	1, 2
SCM5B40-02	-50mV to +50mV	1, 2
SCM5B40-03	-100mV to +100mV	1, 2
SCM5B40-04	-10mV to +10mV	3, 4
SCM5B40-05	-50mV to +50mV	3, 4
SCM5B40-06	-100mV to +100mV	3, 4
SCM5B40-07 <sup>(3)</sup>	-1V to +1V	1, 2
SCM5B41-01	-1V to +1V	1, 2
SCM5B41-02	-5V to +5V	1, 2
SCM5B41-03	-10V to +10V	1, 2
SCM5B41-04	-1V to +1V	3, 4
SCM5B41-05	-5V to +5V	3, 4
SCM5B41-06	-10V to +10V	3, 4
SCM5B41-07	-20V to +20V	1, 2
SCM5B41-08	-20V to +20V	3, 4
SCM5B41-09	-40V to +40V	1, 2
SCM5B41-10	-40V to +40V	3, 4

**†Output Ranges Available**

Output Range	Part No. Suffix	Example
1. -5V to +5V	NONE	SCM5B40-01
2. -10V to +10V	D	SCM5B40-01D
3. 0V to +5V	NONE	SCM5B40-04
4. 0V to +10V	D	SCM5B40-04D