



Measuring converter

AD4RS

4 inputs for standardized signal measuring

0 - 10 V, 0 - 20 mA, 4 - 20 mA

Communication via RS232 or RS485 lines



AD4RS

Datasheet

Created: 4.5.2007

Last update: 6/15/2009 10:17 AM

Number of pages: 12

© 2009 Papouch s.r.o.

Papouch s.r.o.

Address:

**Strasnicka 3164
102 00 Prague 10
Czech Republic**

Tel:

**+420 267 314 267
+420 267 314 268
+420 602 379 954**

Fax:

+420 267 314 269

Internet:

www.papouch.com

E-mail:

info@papouch.com



CONTENT

| | |
|---|----|
| Basic information | 4 |
| Description..... | 4 |
| Application | 4 |
| Features | 4 |
| Block diagram and operation | 5 |
| Examples of connection structure | 5 |
| Voltage measurement..... | 5 |
| Sensors with output of 0 to 20 mA and own power supply | 6 |
| Sensors with output of 0 to 20 mA, supplied through current loop..... | 6 |
| Connectors | 7 |
| Measuring terminals..... | 7 |
| Power supply | 8 |
| RS232..... | 8 |
| RS485..... | 9 |
| Technical parameters | 10 |
| Available Designs | 11 |
| Indications..... | 11 |
| Detailed description of communication protocol | 11 |

BASIC INFORMATION

Description

AD4RS measuring converter is a 4-input A/D converter which enables the user to measure to four current inputs ranging from 0(4) to 20 mA or voltage between 0 and 10 V. The measured values are then transferred to a superior system in digital form. AD4RS has been produced in three versions differing in their communication interface – the data can be transferred via RS232/RS485 lines, over USB interface or the Ethernet. The AD4RS version communicates via RS232 serial line or RS485 bus.



Application

- Measurement of values from sensors with voltage or current output.
- Reading of sensors whose output is a standardised current signal
- Digitalisation of measured values from level, pressure, temperature, distance and other sensors

Features

- Four analogue inputs for current or voltage
- Measuring scale divided into 10 000 divisions
- Full isolation of the measuring part from power supply and communication lines
- Measurements carried out by a multiplex 16 bit sigma-delta A/D converter
- The maximum measuring speed of each input equals 406 ms
- Two measuring modes:
 - Single measurement – sends one measured value from each input upon a request.
 - Continuous measuring – measures all inputs in the set interval and regularly sends the measured values via the communication line.
- Communication via RS232 (COM port) or RS485 (industrial bus)
- Measuring Wix software for temperatures displaying and storing for Windows
- Wide range of power supply voltage (6 to 30 V)

BLOCK DIAGRAM AND OPERATION

The measuring part is fully isolated from the communication line and power supply.

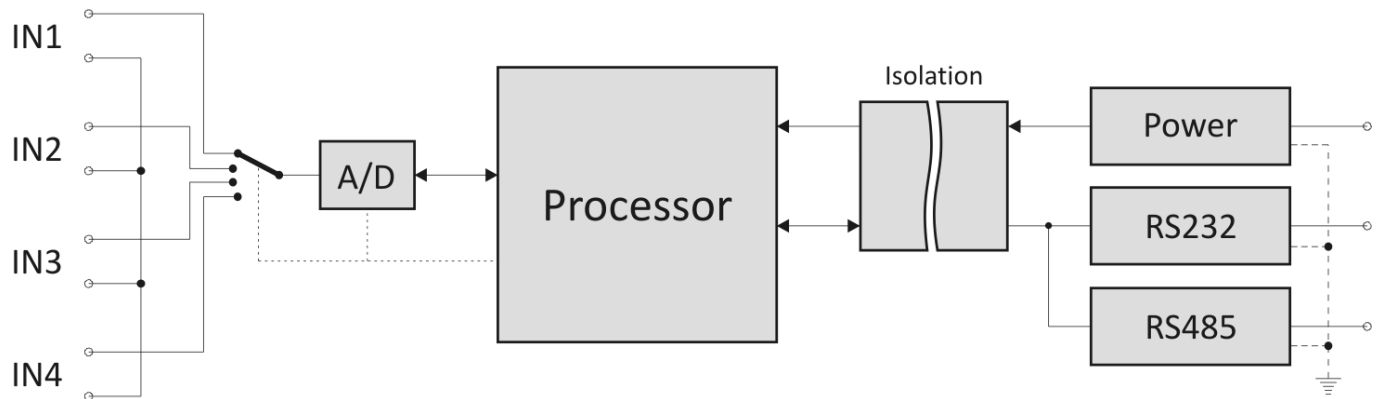

Fig. 1 – Block diagram of AD4RS

The AD4RS measuring device uses one switched sigma-delta A/D converter. After switching on the power supply voltage, the processor initiates the A/D converter and set the device parameters according to the data saved in memory. Then the device start to regularly measure the values of voltage found on the analog inputs and saves the results into the integrated memory.

In the continuous measuring mode AD4RS sends the measured values in the set interval.

EXAMPLES OF CONNECTION STRUCTURE

The following figures show examples of AD4RS connection structure.

Voltage measurement

An example of voltage supply connection to AD4RS terminals. The inputs are fully isolated from the power supply.

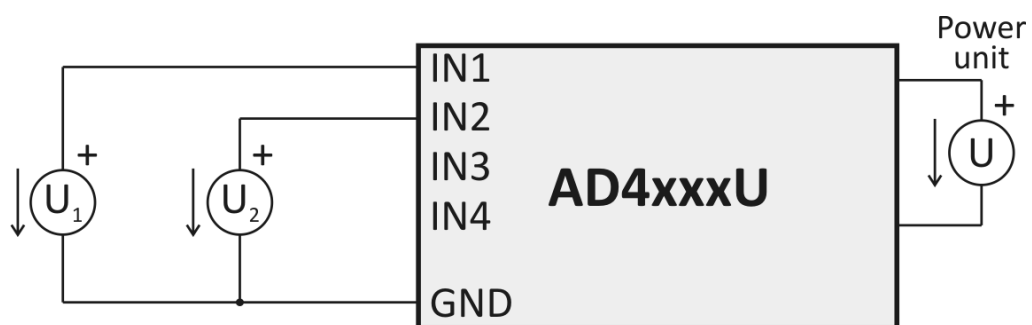

Fig. 2 – Voltage measurement

Sensors with output of 0 to 20 mA and own power supply

Sensors with currents outputs can be connected directly to the inputs with current range and supplied either from their own power supply (in this case, the sensor is isolated from AD4RS power supply) or from the same supply as AD4RS (see the dashed lines in Fig. 3; in this case, sensors are not isolated).

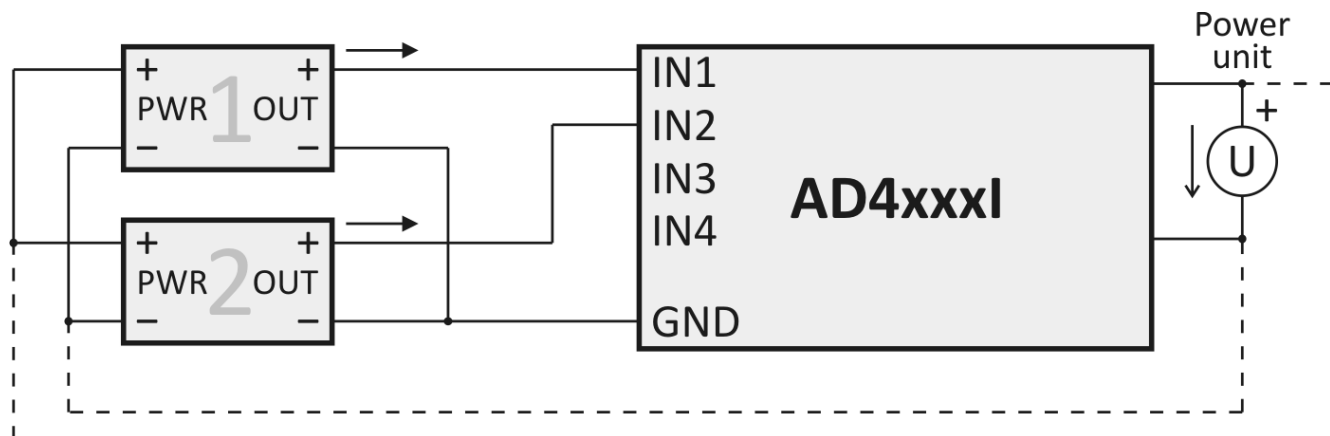

Fig. 3 – Current sensors with their own power supply

Sensors with output of 0 to 20 mA, supplied through current loop

With a separate source for sensors

In this case, the sensors are isolated from AD4RS power supply.

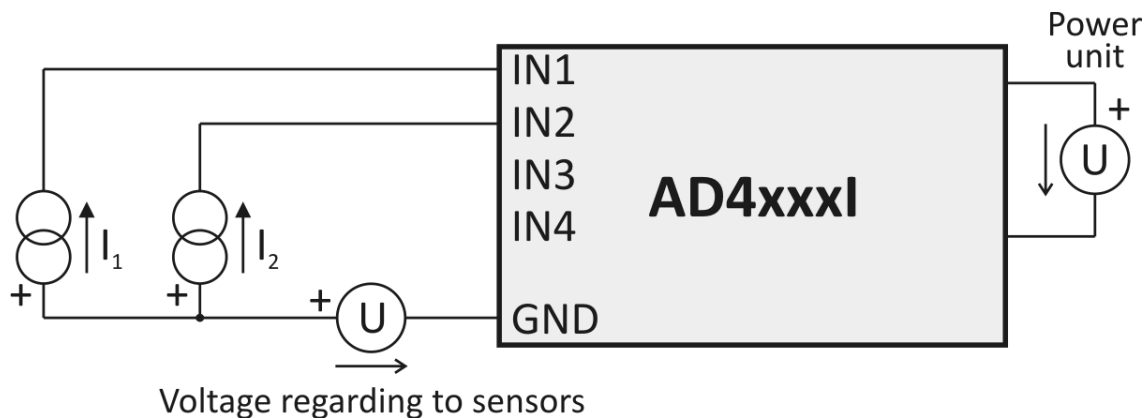

Fig. 4 – Current sensors with separate supply through current loop

With a joint source for sensors and AD4RS

In this case, the sensors are isolated with AD4RS power supply.

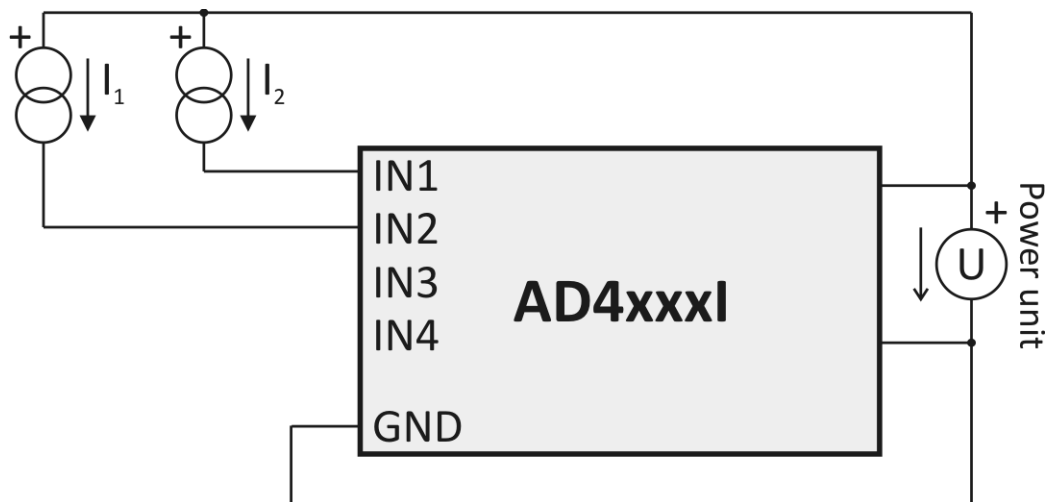

Fig. 5 – Current sensors supplied through current loop from joint source with AD4RS

CONNECTORS

Measuring terminals

Note: The input types (voltage or current) are unchangeable and must be specified by the user when ordering the device. Subsequently they can be changed only by the manufacturer.

The measuring terminal unit is a six-slot terminal unit shown in Figure 6. It contains four inputs and two grounding terminals.

All four measuring terminals have a joint grounding on the two sides of the terminal unit. This grounding is isolated from other grounding terminals found in the device.

The measuring terminals have been designed for the measurement of voltage or current. Wires can be connected individually and fixed by means of a screw (use flat bladed screwdriver 2.5 mm).

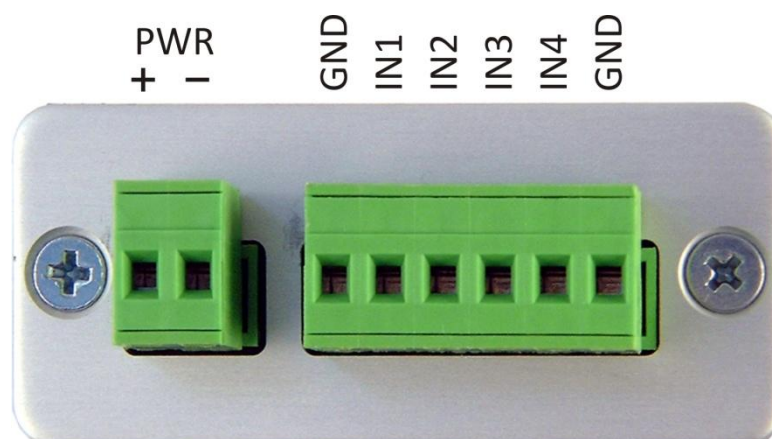

Fig. 6 – Terminals for power supply connection and measuring terminals

Power supply

DC supply 6 to 30 V shall be connected to the double terminal shown in Fig. 6. The input has an integrated polarity reversal protection.

Wires can be connected individually and fixed by means of a screw (use flat bladed screwdriver 2.5 mm).

RS232

RS232 serial line shall be connected via the CAN9F connector (female plug). A usual extension cable is suitable for RS232 connection. The serial line connector is shown in Fig. 7, the connection diagram for individual conductors can be found in Fig. 8.

A simultaneous use of RS232 and RS485 as communication interfaces is possible. AD4RS is able of receive commands only from one line at a time. It is necessary to make sure AD4RS does not receive commands from both RS232 and RS485 simultaneously.

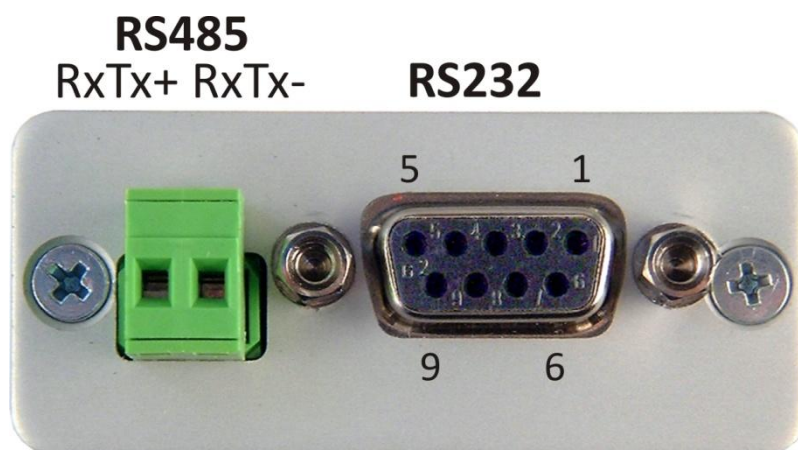

Fig. 7 – Terminals for RS232 and RS485¹ serial lines connection

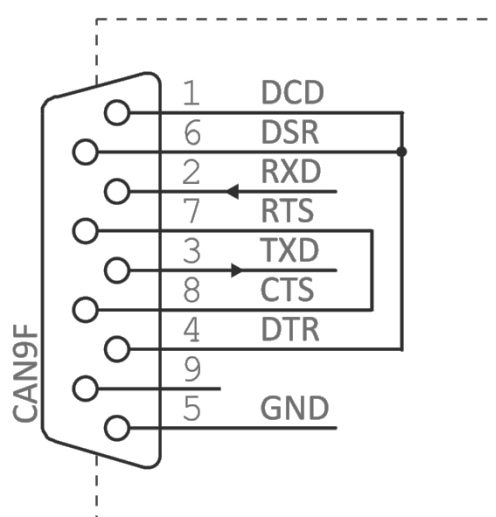

Fig. 8 – RS232 connector diagram

¹ RS485 line conductors are often marked as A (RxTx+) and B (RxTx-).

RS485

The connection to RS485 bus can be made by means of the terminal next to the Cannon connector. The terminal connection is shown in Fig. 7.

A simultaneous use of RS485 and RS232as communication interfaces is possible. AD4RS is able of receive commands only from one line at a time. It is necessary to make sure AD4RS does not receive commands from both RS485 and RS232 simultaneously.

Connection of RS485 termination

It is not necessary to use the termination in most cases. However, if the RS485 communication line runs through interfering environment (it runs in parallel with power conductors etc.) it is suitable to connect the termination. There can be only up to 2 modules with connected termination on one line (at the opposite ends of the line).

Inside the device can be found a jumper which can be shorted out to connect the termination (see Fig. 9). The housing can be opened after unscrewing the screws on the sides.

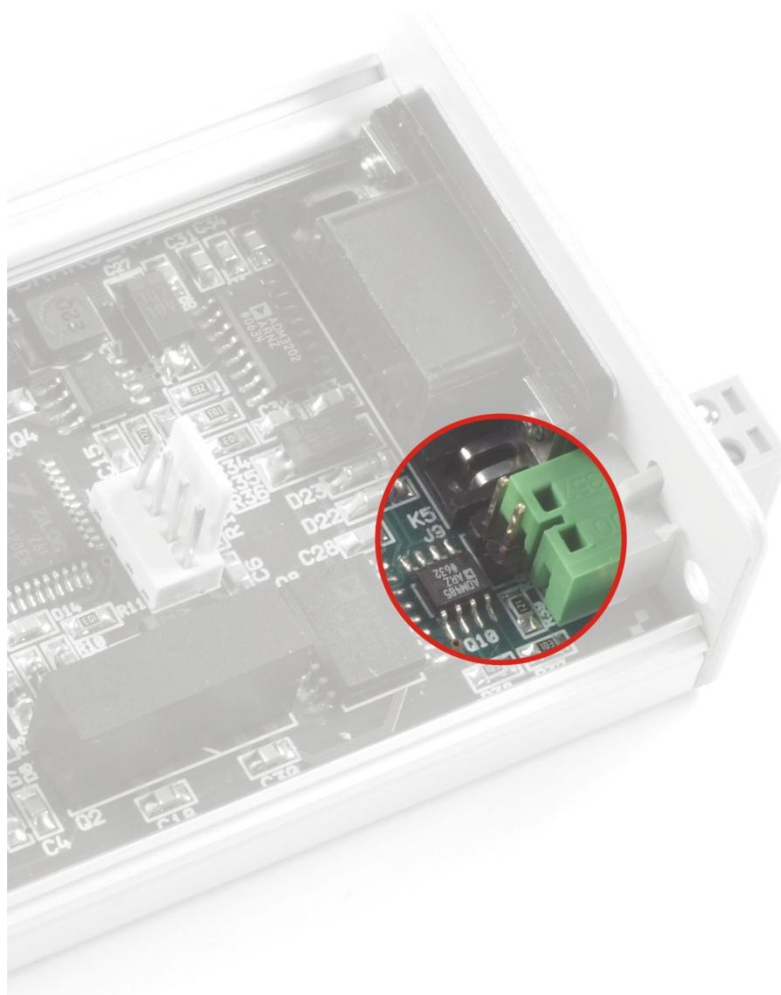

Fig. 9 – Jumper for RS485 termination

TECHNICAL PARAMETERS

Analogous inputs:

| | |
|--|--|
| Number of inputs..... | 4 |
| Input type | unipolar |
| Voltage input range | 0 – 10 V; 10 000 divisions |
| Input impedance (voltage inputs) | 1 M Ω (100 k Ω / 1 V) |
| Current input ranges | 0 – 20 mA; 4 – 20 mA; 10 000 divisions |
| Calibration..... | 10 000 divisions/range |
| A/D converter resolution..... | 16 bits |
| Maximum non-linearity | 10 divisions |
| Maximum zero error | 10 divisions |
| Maximum rang error..... | 10 divisions |
| Maximum measuring speed | 406 ms (all channels) |
| Calibration method | software ² |

Control interface:

| | |
|------------------------------|---|
| Type | RS232 and RS485 |
| Connector | slip-on terminal unit |
| Communication speed | adjustable 300 Bd to 230.4 kBd (default: 9.6 kBd) |
| Number of data bits..... | 8 |
| Parity | no parity |
| Number of stop-bits..... | 1 |
| Isolation..... | \pm 300 V |
| Communication protocol | Spinel |
| Minimum response delay | 2 ms ³ |

Power supply:

| | |
|------------------------|--|
| Supply voltage | DC 6 to 30 V (with polarity reversal protection) |
| Power consumption..... | usually 30 mA at 12 V |

Other parameters:

| | |
|--|--------------------------------------|
| Operation temperature | -20 °C to +70 °C |
| Dimensions | 104 mm \times 55 mm \times 24 mm |
| Dimensions incl. connectors | 121 mm \times 55 mm \times 24 mm |
| Dimensions incl. DIN rail holder | 104 mm \times 55 mm \times 33 mm |

² Calibration is described in greater detail in the communication protocol description which is available to be downloaded from the device web page.

³ Due to the delay when switching the communication direction over to RS485.

Weight145 g

Available Designs

Assembly:

- Without a holder (*standard design*)
- With a DIN rail holder



Fig. 10 - AD4RS with DIN rail holder

- With a wall holder



Fig. 11 – AD4 with wall holder

Input ranges:

- 0 to 10 V
- 0 to 20 mA
- 4 to 20 mA
- It is possible to deliver another current or voltage range upon request; it is also possible to combine more ranges in one device

Do not hesitate to contact us in case of any other special requirements concerning the AD4RS module design and functions.

INDICATIONS

The device contains three light indicators showing the operational status:

ON

Green light. Lights when the supply voltage is connected.

COM

Yellow light. Flashes once after the device initiation following the power supply switch-on and also during communication running on RS232 or RS485.

OVR

Red light. Flashes repeatedly when the input range of any channel has been exceeded.

DETAILED DESCRIPTION OF COMMUNICATION PROTOCOL

The detailed description of Spinel communication protocol used by AD4RS is available for downloading from the AD4RS web page.

Papouch s.r.o.

Data transmission in industry, line and protocol conversions, RS232/485/422/USB/Ethernet/GPRS/WiFi, measurement modules, intelligent temperature sensors, I/O modules, and custom-made electronic applications.

Address:

**Strasnicka 3164
102 00 Prague 10
Czech Republic**

Tel:

**+420 267 314 267
+420 267 314 268
+420 602 379 954**

Fax:

+420 267 314 269

Internet:

www.papouch.com

E-mail:

info@papouch.com

