

DSCA49

Voltage Output Signal Conditioners



Description

Each DSCA49 voltage output module provides a single channel of analog output. The input signal is buffered, isolated, filtered and converted to a voltage output (Figure 1). Signal filtering is accomplished with a five-pole filter which provides 100dB per decade of attenuation above 1kHz. An anti-aliasing pole is located on the system side of the isolation barrier, and the other four poles are on the field side. After the initial system-side filtering, the input signal is chopped by a proprietary chopper circuit. Isolation is provided by transformer coupling, again using a proprietary technique to suppress transmission of common mode spikes or surges.

Special output circuits provide protection against accidental connection of power-line voltages up to 240VAC and against transient events as defined by ANSI/IEEE C37.90.1. Protection circuits are also present on the signal input and power input terminals to guard against transient events and power reversal. Signal and power lines are secured to the module using screw terminals which are in pluggable terminal blocks for ease of system assembly and reconfiguration.

The modules have excellent stability over time and do not require recalibration, however, zero and span settings are adjustable up to $\pm 5\%$ to accommodate situations where fine-tuning is desired. The adjustments are made using potentiometers located under the front panel label and are non-interactive for ease of use.

► Features

- Accepts High-Level Voltage Input
- Provides High-Level Voltage Outputs to $\pm 10V$ at 50mA
- ANSI/IEEE C37.90.1
- 1500Vrms Transformer Isolation
- $\pm 0.05\%$ Accuracy
- $\pm 0.02\%$ Linearity
- Output Protected to 240VAC Continuous
- True 3-Way Isolation
- Wide Range of Supply Voltage
- 110dB CMR
- Easily Mounts on Standard DIN Rail
- C-UL-US Listed
- CE and ATEX Compliant

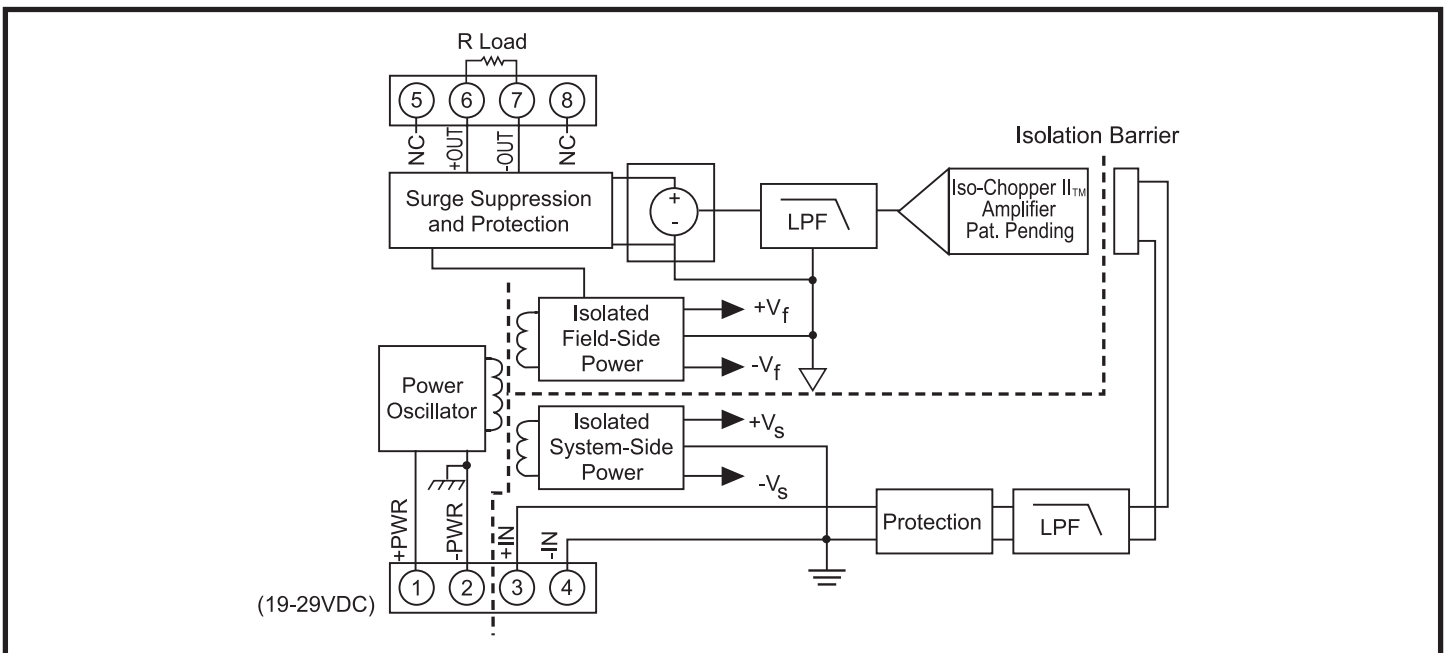

Figure 1: DSCA49 Block Diagram

Specifications Typical* at T_A=+25°C and +24VDC supply voltage

Module	DSCA49-04, -05, -06
Output Range	0 to +10V or -10 to +10V
Over Range Capability	5%
Output Drive	±50mA max.
Output Resistance	0.5Ω
Output Current Limit	75mA
Output Protection	
Continuous	240Vrms max
Transient	ANSI/IEEE C37.90.1
Input Range	0V to +10V or -10V to +10V
Input Resistance	
Normal	50MΩ
Power Off	65kΩ
Overload	65kΩ
Input Protection	
Continuous	±35V max
Transient	ANSI/IEEE C37.90.1
CMV, Output to Input, Output to Power	
Continuous	1500Vrms max
Transient	ANSI/IEEE C37.90.1
CMV, Input to Power	
Continuous	50VDC max
CMR (50Hz or 60Hz)	110dB
Accuracy ⁽¹⁾	±0.05% Span
Linearity	±0.02% Span
Adjustability	±5% Zero and Span
Stability	
Zero	±20ppm/°C
Span	±40ppm/°C
Output Noise, 100kHz Bandwidth	2mVrms
Bandwidth, -3dB	1kHz
NMR	100dB/Decade Above 1kHz
Response Time, 90% Span	425μs
Power Supply	
Voltage	19 to 29VDC
Current	80mA
Sensitivity	±0.0003%/%
Protection	
Reverse Polarity	Continuous
Transient	ANSI/IEEE C37.90.1
Environmental	
Operating Temperature Range	-40°C to +80°C
ATEX Group II, Category 3	-40°C to +75°C
Storage Temperature Range	-40°C to +80°C
Relative Humidity	0 to 95% Noncondensing
Emissions EN61000-6-4	ISM, Group 1
Radiated, Conducted	Class A
Immunity EN61000-6-2	ISM, Group 1
RF	Performance A ±0.5% Span Error
ESD, EFT	Performance B
Mechanical Dimensions	
(h)(w)(d)	2.95" x 0.89" x 4.13" (75mm x 22.5mm x 105mm)
Mounting	DIN EN 50022 -35x7.5

NOTES:

* Contact factory or your local Dataforth sales office for maximum values.

(1) Includes linearity, hysteresis and repeatability.

Installation Notes:

- 1.) This Equipment is Suitable for Use in Class I, Division 2, Groups A, B, C, D, or Non-Hazardous Locations Only.
- 2.) Warning - Explosion Hazard - Substitution of Components May Impair Suitability for Class I, Division 2.
- 3.) Warning - Explosion Hazard - Do Not Disconnect Equipment Unless Power Has Been Switched Off or The Area is Known to be Non-Hazardous.

Ordering Information

Model	Input Range	Output Range
DSCA49-04	0V to +10V	-10V to +10V
DSCA49-05	-10V to +10V	-10V to +10V
DSCA49-06	-10V to +10V	0V to +10V