

# Q.brixx XE A156

Measurement Module for Strain Gage and LVDT/RVDT

Q.brixx XE is a new addition to the Q.series product family - the ideal EtherCAT DAQ solution for on-the-go applications in potentially harsh environments. Q.brixx XE DAQ systems consist of up to 10 measurement modules capable of up to 100 kHz sampling per channel and an integrated EtherCAT bus coupler providing short cycle times and low jitter for accurate synchronization, all within a robust aluminum housing capable of withstanding severe shock and vibration without sacrificing performance.

- DC (distributed clock) for data synchronization
- FoE (file access over EtherCAT, ETG.1000.5) and CoE (CAN over EtherCAT, ETG.50001.1)
- Configurable PDO mapping to optimize the data throughput
- Electromagnetic Compatibility according to EN61000-4 and EN55011
- Power supply 10 ... 30 VDC

## Key Features

- 4 galvanically isolated analog inputs channels strain gage and inductive half and full bridges, LVDT, RVDT quarter bridge with completion terminal
- Carrier frequency (CF) principle  
4.8 kHz carrier frequency
- High-accuracy digitization  
24 bit ADU, 20 kHz sample rate per channel
- Signal conditioning  
linearization, filtering, average, scaling, min/max, RMS, arithmetic, alarm
- 3-Way galvanic isolation  
Channel to channel, channel to power supply, and channel to bus

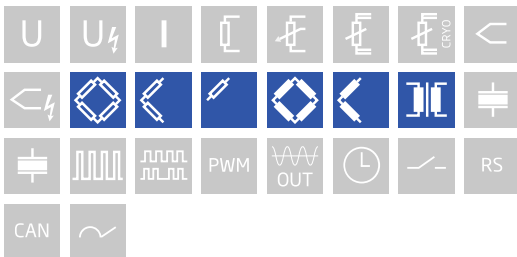

### Block diagram

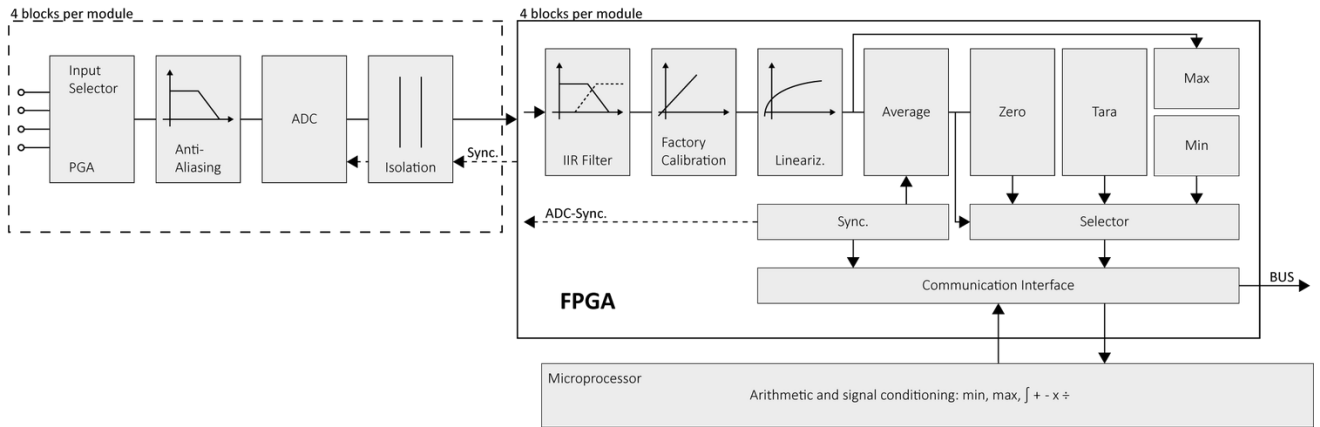

### Technical Data

#### Terminal assignment 10pole screw

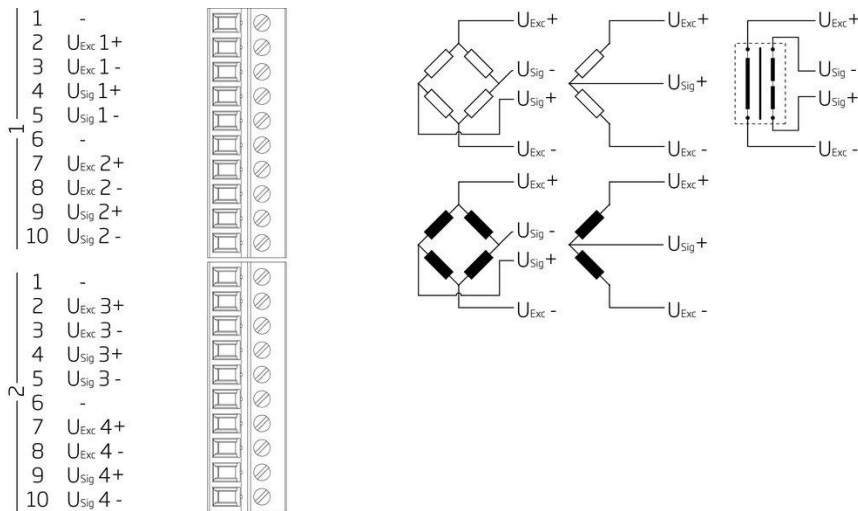

### Analog Input

Channels	4
Accuracy	0.02 % typical
	0.05 % in controlled environment <sup>1</sup>
	0.1 % in industrial area <sup>2</sup>
Linearity error	0.02 % typical full-scale
Repeatability	0.01 % typical (within 24 hrs)
Input impedance	>10 M $\Omega$
Isolation voltage	500 VDC channel to channel, to power supply, channel to bus <sup>3</sup>

<sup>1</sup> according to EN 61326 2006: appendix B

<sup>2</sup> according to EN 61326 2006: appendix A

<sup>3</sup> noise pulses up to 1000 VDC, continuous up to 250 VDC

### Strain Gage Measurement

Bridge configuration(s)	resistive full-bridge (4/wire) resistive half-bridge (3/wire)	
Allowable sensor cable length	< 30 m	
Shunt resistor	100 kΩ internal resistor	
Bridge excitation	2.5 or 5 V <sub>eff</sub> , 4.8 kHz AC excitation	
Bridge excitation stability	< 0.01% / 24 hrs	
Bridge excitation drift	< 0.02% / 10 K	
	<b>5 V<sub>eff</sub></b>	<b>2.5 V<sub>eff</sub></b>
Allowable sensor resistance	> 300 Ω	> 100 Ω
Input range	±1.25 mV/V	±2.5 mV/V
	±2.5 mV/V	±5 mV/V
	±25 mV/V	±50 mV/V
	±50 mV/V	±100 mV/V
	±100 mV/V	±200 mV/V
	±200 mV/V	±400 mV/V
	±500 mV/V	±1000 mV/V
Long-term stability	< 0.1 μV/V / 24 hrs	< 1 μV/V / 8000 hrs
Temperature drift (range 2.5 mV/V)	< 0.2 μV/V / 10 K Offset drift	< 0.05 % / 10 K Gain drift
Noise (range 2.5 mV/V)	0.3 μV/V at 0 up to 10 Hz	1 μV/V at 10 up to 1 kHz

### LVDT/RVDT Measurement

Sensor connection	3- / 4-wire	
Sensor excitation (selectable)	<b>5 V<sub>eff</sub></b>	<b>2.5 V<sub>eff</sub></b>
Allowable sensor resistance	> 300 Ω	> 100 Ω
Input range	±1.25 mV/V	±2.5 mV/V
	±2.5 mV/V	±5 mV/V
	±25 mV/V	±50 mV/V
	±50 mV/V	±100 mV/V
	±100 mV/V	±200 mV/V
	±200 mV/V	±400 mV/V
	±250 mV/V	±500 mV/V
	±500 mV/V	±1000 mV/V
Allowable sensor cable length	< 100 m <sup>1</sup>	
Long-term stability	< 0.1 μV/V / 24 hrs	< 1 μV/V / 8000 hrs
Temperature drift (range 2.5 mV/V)	< 0.2 μV/V / 10 K Offset drift	< 0.05 % / 10 K Gain drift
Signal-to-noise ratio	< 0.3 μV/V at 10 Hz	< 1 μV/V at 100 Hz

<sup>1</sup> low capacity sensor cable is strongly recommended

# Q.brixx XE A156

Measurement Module for Strain Gage and LVDT/RVDT

## Analog-to-Digital Conversion

Resolution	24-bit
Sample rate	20 kHz per channel
Modulation method	sigma-delta
Anti-aliasing filter	1 kHz, 3th order (4.8 kHz CF excitation)
Digital filters	Infinite impulse response (IIR), low-pass, high-pass, band-pass, band-stop, Butterworth or Bessel (2nd, 4th, 6th or 8th order), frequency range 0.1 Hz to 1 kHz in steps of 0.1 (adjustable via software)
Averaging	configurable or automatic according to the user-defined data rate

## Communication Interface EtherCAT

Electrical standard	RS-485, 2-wire
Protocols	EtherCAT (LVDS)

## Power Supply

Input voltage	10 to 30 VDC, overvoltage and overcurrent protection
Power consumption	2.5 W (approx.)
Input voltage influence	<0.001 % / V

## Environmental Specifications

Electromagnetic compatibility (EMC)	according to IEC 61000-4 and EN 55011
Operating temperature	-20°C to +60°C
Storage temperature	-40°C to +85°C
Relative humidity	5 - 95 % at 50°C (non-condensing)

## Remarks

are subject to a warm-up period of at least 45 minutes

Specifications subject to change without notice

## Mechanical information

Material	Aluminum
Measurements (W x H x D)	30x 137 x 135mm
Weight	approx. 500 g
Protection class	IP40

## Ordering Information

Article number	676330
----------------	--------

## Gantner Instruments

Austria | Germany | France | Sweden | India | USA | China | Singapore  
Montafonerstraße 4 · A-6780 Schruns · T +43 55 56 · 77 463-0

office@gantner-instruments.com  
www.gantner-instruments.com