

Q.brixx XE A127 2CV

Module for Measuring Electrical Power

Q.brixx XE is a new addition to the Q.series product family - the ideal EtherCAT DAQ solution for on-the-go applications in potentially harsh environments. Q.brixx XE DAQ systems consist of up to 10 measurement modules capable of up to 100 kHz sampling per channel and an integrated EtherCAT bus coupler providing short cycle times and low jitter for accurate synchronization, all within a robust aluminum housing capable of withstanding severe shock and vibration without sacrificing performance.

- DC (distributed clock) for data synchronization
- FoE (file access over EtherCAT, ETG.1000.5) and CoE (CAN over EtherCAT, ETG.50001.1)
- Configurable PDO mapping to optimize the data throughput
- Electromagnetic Compatibility according to EN61000-4 and EN55011
- Power supply 10 ... 30 VDC



Key Features

- 2 voltage input channels
measuring ranges ± 40 V, ± 120 V, ± 400 V, ± 1200 V
- 2 current input channels
measuring ranges ± 200 mA, ± 400 mA, ± 800 mA
- Sensor Supply
 ± 15 V, Accuracy 0.2 V
- Signal conditioning
linearization, digital filter, average, scaling, min/max storage, RMS, alarm
- Fast high accuracy digitalization
24 bit ADC, 100 kHz sample rate per channel
- Galvanic isolation
channel to channel to power supply and to interface
- Categories
1000 V CAT II and 600 V CAT III

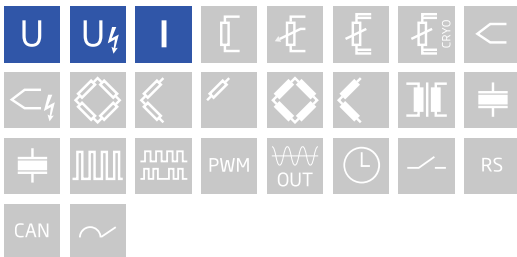

Q.brixx XE A127 2CV

Module for Measuring Electrical Power

Block diagram

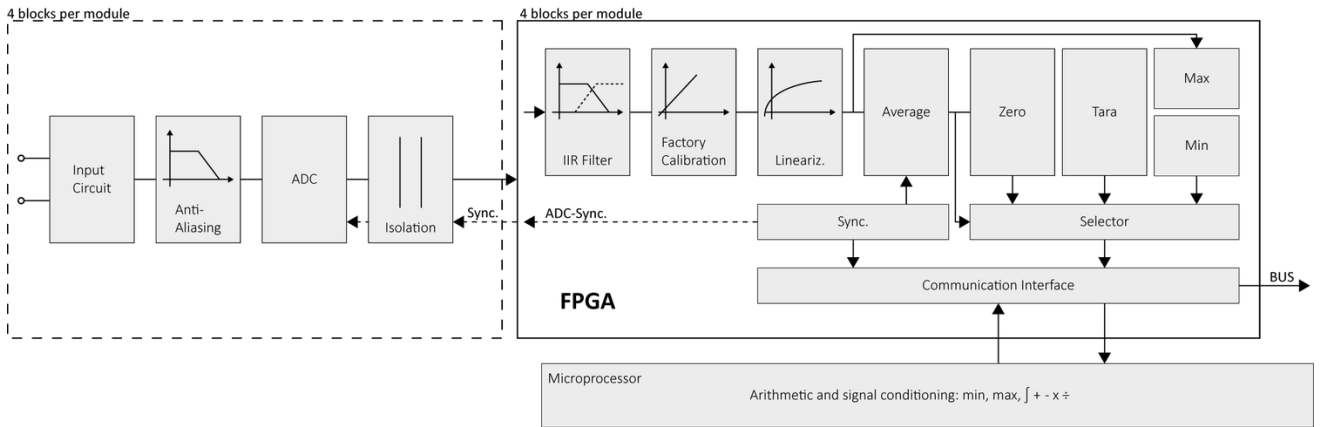

Technical Data

Terminal assignment high voltage banana + DSub 9 female

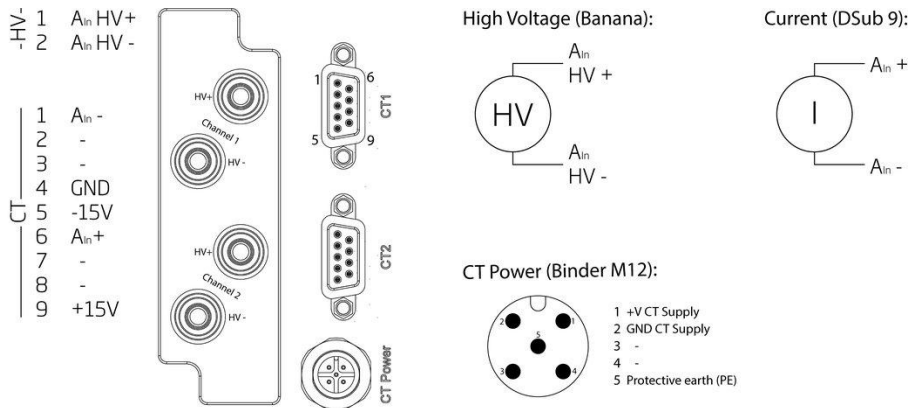

Analog Inputs

Channels	4
Isolation voltage	1200 VDC continuous, channel to channel to power supply channel to bus ¹

¹ High voltage lifetime (TDD B E Model). Time to fail approx.. 4 years at 1200 VDC and 60 °C continuous

Measurement Mode Voltage AI1 + AI3

Range	± 1200 V	± 400 V	± 120 V	± 40 V
Accuracy	± 300 mV	± 100 mV	± 30 mV	± 10 mV
Resolution	300 µV	100 µV	30 µV	10 µV
Long-term offset stability	30 mV / 24 h	10 mV / 24 h	3 mV / 24 h	1 mV / 24 h
	100 mV / 8000 h	30 mV / 8000 h	10 mV / 8000 h	3 mV / 8000 h
Offset temperature influence	100 mV / 10k	30 mV / 10 k	10 mV / 10 k	3 mV / 10
temperature influence	0.025 % / 10K			
Input impedance	> 10 MΩ			

Q.brixx XE A127 2CV

Module for Measuring Electrical Power

Measurement Mode Current

Range	± 800 mA	± 400 mA	± 200 mA
Accuracy	± 160 µA	± 80 µA	± 40 µA
Resolution	200 nA	100 nA	50 nA
Long-term offset stability	20 µA / 24 h	10 µA / 24 h	5 µA / 24 h
	80 µA / 8000 h	40 µA / 8000 h	20 µA / 8000 h
Offset temperature influence	60 µA / 10 K	30 µA / 10 K	15 µA / 10 K
Temperature influence	0.025% / 10 K		
Input impedance	1 Ω		

Sensor Supply

Input voltage	10 to 30 VDC
Output voltage	± 15 V
Accuracy	0.2 V
Max. current	800 mA
Noise	10 mV RMS
temperature influence	20 mV / 10 K

Analog/Digital-Conversion

Resolution	24-bit
Update rate	100 kHz
Modulation method	Sigma-Delta
Anti-aliasing filter	20 kHz, 3rd order
Digital filters	Infinite impulse response (IIR), low-pass, high-pass, band-pass, Butterworth or Bessel (2nd, 4th, 6th or 8th order), frequency range 0.1 Hz to 10 kHz (adjustable via software)
Averaging	configurable or automatic according to the selected data rate

Communication Interface EtherCAT

Electrical standard	RS-485, 2-wire
Protocols	EtherCAT (LVDS)

Power Supply

Input voltage	10 to 30 VDC, overvoltage and overcurrent protection
Power consumption	approx.. 2 W
Input voltage influence	<0.001 %/V

Remarks

Are subject to a warm-up period of at least 45 minutes

in a controlled electromagnetic environment¹

With configuration: Low-pass 10Hz²

Specifications subject to change without notice

¹ according to EN 61326 2006: appendix B

² according to EN 61326 2006: appendix A

Q.brixx XE A127 2CV

Module for Measuring Electrical Power

High Voltage Warnings



- Attention! High voltage device! - Danger to life and health in case of non regular use.
- Only special and sufficient educated persons are permitted to handle this device only.
- All metal housing parts must be safe and permanently connected to protected earth PE.
- Only contact protection plugs and cables may be used. All parts must be approved for voltages up to 1200 VDC.
- During installation, the whole system must be without voltage and safely be disconnected from the mains.
- All relevant safety regulations must be considered.
- Do not operate with damaged casing.

Base is the european standard EN61010-1

Mechanical Information

Material	Aluminum
Measurements (W x H x D)	60 x 137 x 160mm
Weight	approx. 500 g
Protection class	IP40

Ordering Information

Article number	759130
----------------	--------

Gantner Instruments

Austria | Germany | France | Sweden | India | USA | China | Singapore
Montafonerstraße 4 · A-6780 Schruns · T +43 55 56 · 77 463-0

office@gantner-instruments.com
www.gantner-instruments.com