

Q.bloxx XE A101

Universal Measurement Module

Q.bloxx XE is a new addition to the Q.series product family - the ideal EtherCAT DAQ solution for widely distributed installations that require higher performance and custom sensor terminations. Q.bloxx XE measurement modules possess integrated signal conditioning and arithmetic functions, packaged in modular, DIN Rail mountable enclosures that easily snap together for system expansion and are capable of measuring up to 100 kHz per channel with short cycle times and low jitter for accurate synchronization.

- RS-485, 2-wire, EtherCAT (LVDS)
- FoE (file access over EtherCAT, ETG.1000.5) and CoE (CAN over EtherCAT, ETG.50001.1)
- Configurable PDO mapping to optimize the data throughput
- Electromagnetic Compatibility according to EN61000-4 and EN55011
- Power supply 10 ... 30 VDC and DIN rail mounting (EN60715)



Key Features

- **2 Universal analog input channels**
Voltage, current, resistance, potentiometer, RTD, thermocouple, strain gage (full-, half-, and quarter-bridge configuration), IEPE
- **High-accuracy digitization**
24-bit ADC, 100 kHz sample rate per channel
- **2 Digital inputs or outputs**
Status, trigger, tare, alarm, command
- **Signal conditioning**
16 virtual channels, linearization, digital filter, average, scaling, min/max storage, RMS, arithmetic, alarm
- **3-Way galvanic isolation**
Channel to channel, channel to power supply, and bank

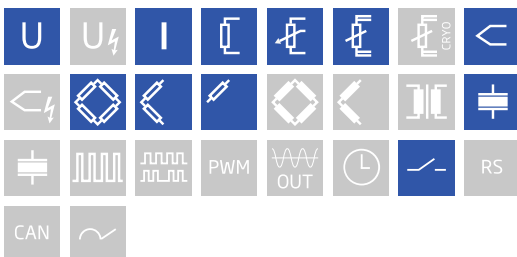

Q.bloxx XE A101

Universal Measurement Module

Block diagram

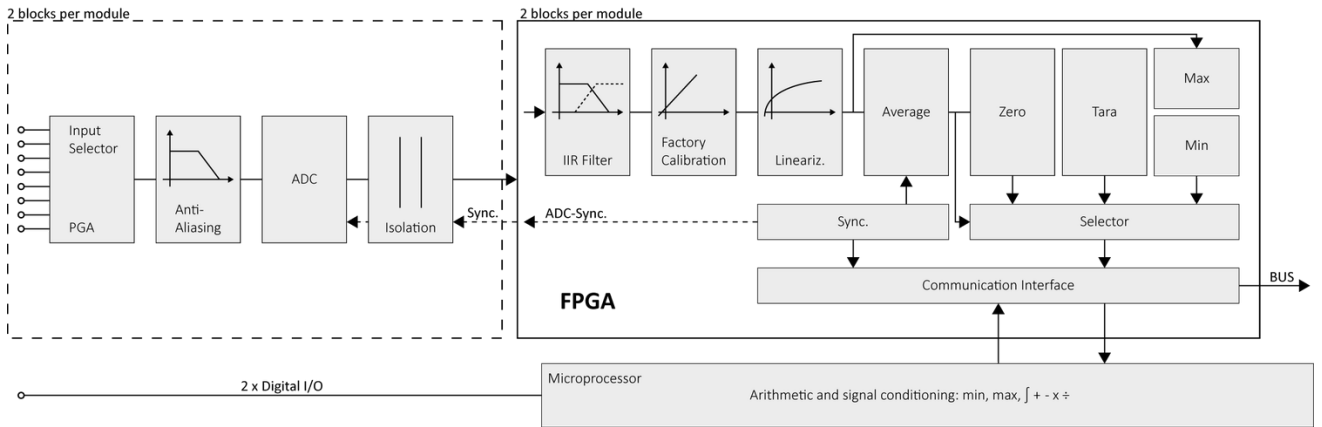

Technical Data

Terminal assignment 10pole screw

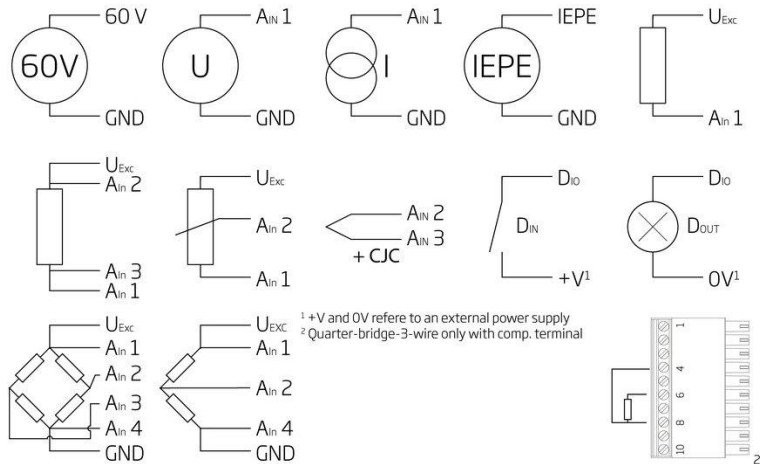
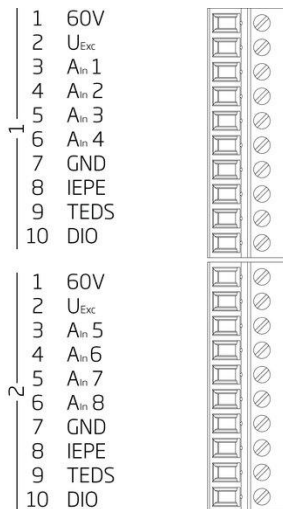

Analog Input

Channels	2
Isolation voltage	500 VDC channel to channel to power supply channel to bus ¹

¹ noise pulses up to 1000 VDC, continuous up to 250 VDC

Measurement Mode Voltage

	Range	max. Error	Resolution
	±60 V	±15 mV	7.2 µV
	±10 V	±2 mV	1.2 µV
	±1 V	±200 µV	120 nV
	±100 mV	±20 µV	12 nV
Input impedance > 10 MΩ	Range ±10 V	Range ±60 V	
	> 1 MΩ	> 3 MΩ	
Long-term drift at input range ± 1 V	< 20 µV / 24 h	< 200 µV / 8000 h	
Temperature influence at input range ± 1 V	Offset drift		Gain drift
	< 50 µV / 10 K	< 0.01 % / 10 K	
Signal-to-noise ratio	> 90 dB at 1 kHz	> 120 dB at 1 Hz	

Measurement Mode Current

	Range	max. Error	Resolution
Internal shunt resistor 50 Ω	±25 mA	±5 µA	3.0 nA
Long-term drift	< 0.5 µA / 24 h	< 5 µA / 8000 h	
Temperature influence	Offset drift		Gain drift
	< 1 µA / 10 K	< 0.025 % / 10 K	

Measurement Mode Resistance / RTD

	Range	max. Error	Resolution
Resistance, 2-wire	100 kΩ	±100 Ω	12 mΩ
Resistance, 2- and 4-wire	4 kΩ	±1 Ω	0.5 mΩ
Resistance, 2- and 4-wire	400 Ω	±0.1 Ω	48 µΩ
Pt100, 2- and 4-wire	-200 to +850°C	±0.25°C	0.2 m°C
Pt1000, 2- and 4-wire	-200 to +850°C	±1°C	0.2 m°C
Long-term drift	< 0.01°C / 24 h	< 0.1°C / 8000 h	
Temperature influence	Offset drift (range 400 Ω)		Gain drift
	< 10 mΩ / 10 K	< 0.025 % / 10 K	

Measurement Mode Potentiometer, Relative Measurement

Allowable potentiometer resistance	1 kΩ to 10 kΩ		
Long-term drift	< 0.01 % / 24 h	< 0.1 % / 8000 h	
Temperature influence	Offset drift (Range 1)		Gain drift
	< 0.0001 / 10 K	< 0.02 % / 10 K	

Measurement Mode Bridge

Bridge configuration(s)	half- and full-bridge, (5-/6-wire), quarter-bridge with completion terminal, (3-wire)		
Accuracy class	0.05		
Bridge resistance	>100 Ω		
Bridge excitation	2.5 VDC, nominal		
Measurement range	±2.4 mV/V	±20 mV/V	±500 mV/V
Long-term drift	<0.12 μV/V / 24 h	<1.2 μV/V / 8000 h	
Temperature influence	Offset drift (Range 2.4 mV/V)		Gain drift
	<0.2 μV/V / 10 K	<0.05 % / 10 K	

Measurement Mode Thermocouple

Deviation in the relevant Temperature range	Type	Range	Adjusted with cold junction compensation	Not adjusted, with CJC terminal
	Type B	400°C to 1820°C	< ±1.5 °C	< ±2.5°C
	Type E, J, K	-100 to 1000°C	< ±0.7°C	< ±1.2°C
	Type E	-270°C to 1000°C	< ±1°C	< ±1.2°C
	Type K	-270°C to 1372°C	< ±1°C	< ±1.2°C
	Type L	-200°C to 900°C	< ±0.7°C	< ±1.2°C
	Type N	-100°C to 1000°C	< ±0.7°C	< ±1.2°C
	Type N	-270°C to 1300°C	< ±1°C	< ±1.2°C
	Type R, S	-50°C to 1768°C	< ±1.2°C	< ±1.5°C
	Type T, U	-100°C to 400°C	< ±0.7°C	< ±1.2°C
	Type T	-270°C to 400°C	< ±1°C	< ±1.2°C
Input impedance	> 10 MΩ			
Long-term drift	<0.1°C / 24 h		<0.2°C / 8000 h	
Temperature influence	Offset drift		Gain drift	
	<0.1°C / 10 K		<0.02% / 10 K	
Uncertainty CJC	<0.3°C			

Measurement Mode IEPE Sensor

Error	Range	max. Error	Resolution
	±10 V	±10 mV	1.2 μV
	±1 V	±1 mV	120 nV
Supply	constant current 4 mA		
Input frequency range	0.5 Hz to 20 kHz		
Temperature influence	Offset drift (range 10 V)		Gain drift
	<10 μV / 10 K		<0.025 % / 10 K

Analog to Digital Conversion

Resolution	24-bit
Update rate	100 kHz (measurement thermocouple 8 Hz)
Modulation method	Sigma-Delta
Anti-aliasing filter	20 kHz, 3rd order
Digital filters	Infinite impulse response (IIR), low-pass, high-pass, band-pass, Butterworth or Bessel (2nd, 4th, 6th or 8th order), frequency range 0.1 Hz to 10 kHz (adjustable via software)
Averaging	configurable or automatic according to the selected data rate

Digital In-/Outputs

Channels	2 (1 digital I/O per channel)
Response time	0.2 ms
Input	status, tare, reset
Input voltage / input current	max. 30 VDC / max. 0,5 mA
Lower / upper threshold	< 2.0 V (low) / > 10 V (high)
Output	status, alarm
Contact	open drain p-channel MOSFET
Load capacity	30 VDC / 100 mA (ohmic load)

Communication Interface

Electrical standard	RS-485, 2-wire
Protocols	EtherCAT (LVDS)

Power Supply

Input voltage	10 to 30 VDC, overvoltage and overcurrent protection
Power consumption	approx.. 2 W
Input voltage influence	< 0.001 %/V

Environmental

Operating temperature	-20°C to +60°C
Storage temperature	-40°C to +85°C
Relative humidity	5 % to 95 % at 50°C, non-condensing

Remarks

Are subject to a warm-up period of at least 45 minutes

in a controlled electromagnetic environment¹

With configuration: Low-pass 10Hz²

Specifications subject to change without notice

¹ according to EN 61326 2006: appendix B

² according to EN 61326 2006: appendix A

Q.bloxx XE A101

Universal Measurement Module

Mechanical information

Material	Aluminum and ABS
Measurements (W x H x D)	30x 145 x 135mm
Weight	approx. 500 g
Protection class	IP20

Ordering Information

Article number	498837
Accessories	Terminal B4/120-A101, article number 897895
	Terminal B4/350-A101, article number 897996
	Terminal CJC-A101, article number 890787

Gantner Instruments

Austria | Germany | France | Sweden | India | USA | China | Singapore
 Montafonerstraße 4 · A-6780 Schruns · T +43 55 56 · 77 463-0

office@gantner-instruments.com
 www.gantner-instruments.com