

# Q.brixx XE A107 SV

## Universal Measurement Module

Q.brixx XE is a new addition to the Q.series product family - the ideal EtherCAT DAQ solution for on-the-go applications in potentially harsh environments. Q.brixx XE DAQ systems consist of up to 10 measurement modules capable of up to 100 kHz sampling per channel and an integrated EtherCAT bus coupler providing short cycle times and low jitter for accurate synchronization, all within a robust aluminum housing capable of withstanding severe shock and vibration without sacrificing performance.

- DC (distributed clock) for data synchronization
- FoE (file access over EtherCAT, ETG.1000.5) and CoE (CAN over EtherCAT, ETG.50001.1)
- Configurable PDO mapping to optimize the data throughput
- Electromagnetic Compatibility according to EN61000-4 and EN55011
- Power supply 10 ... 30 VDC



### Key Features

- 4 Universal analog input channels  
voltage, current, resistance, potentiometer, RTD (Pt100 / Pt1000), thermocouple, strain gage
- Sensor supply for each channel
- High-accuracy digitization  
24-bit ADC, 20 kHz sample rate per channel
- Signal conditioning  
linearization, filtering, average, scaling, min/max, RMS, arithmetic, alarm
- 3-Way galvanic isolation  
Channel to channel, channel to power supply, and channel to bus
- Electromagnetic compatibility (EMC)  
according to IEC 61000-4 and EN 55011

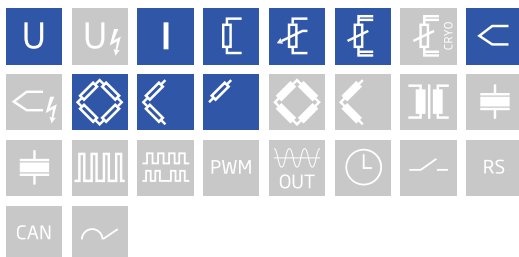

# Q.brixx XE A107 SV

Universal Measurement Module

## Block diagram

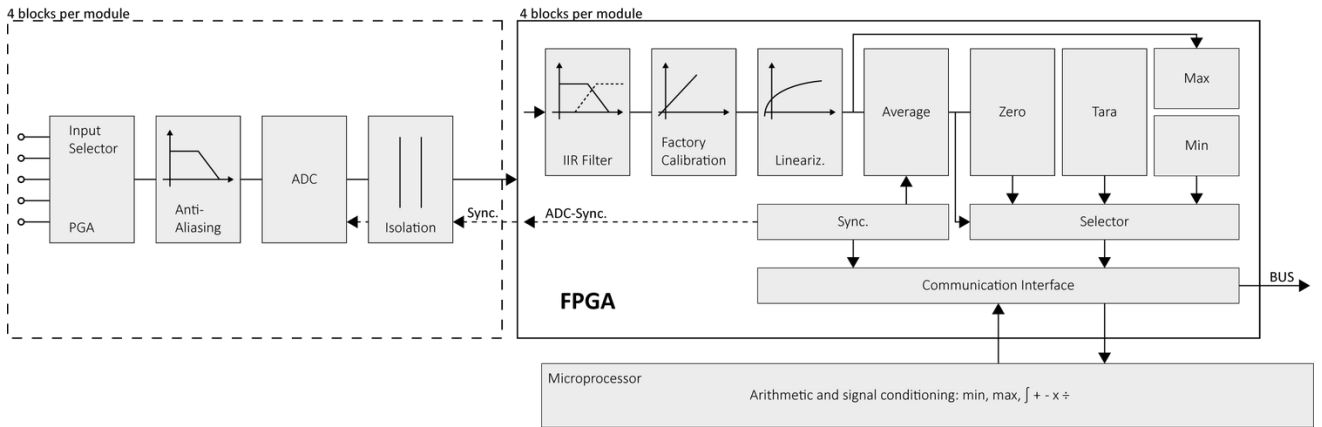

## Technical Data

### Terminal assignment LEMO 2B

- |   |                   |
|---|-------------------|
| 1 | SV1+              |
| 2 | SV GND            |
| 3 | UF                |
| 4 | A <sub>in</sub> 1 |
| 5 | A <sub>in</sub> 2 |
| 6 | A <sub>in</sub> 3 |
| 7 | GND               |
| 8 | -                 |

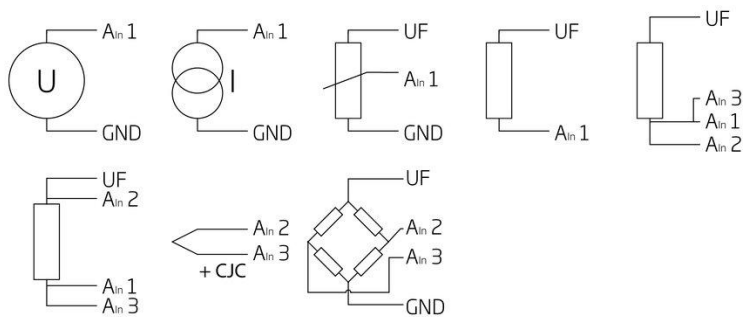
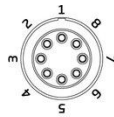

## Analog Input

Channels	4
Isolation voltage	500 VDC channel to channel, to power supply, channel to bus <sup>1</sup>

<sup>1</sup> noise pulses up to 1000 VDC, continuous up to 250 VDC

### Voltage Measurement

Range and error	input range	margin of error	resolution
	±10 V	±2 mV	1.2 µV
	±1 V	±200 µV	120 nV
	±100 mV	±20 µV	12 nV
Long-term stability	input range	24 hrs	8000 hrs
	±10 V	<200 µV	<2000 µV
	±1 V	<20 µV	<200 µV
	±100 mV	<2 µV	<20 µV
Temperature drift	input range	Offset drift	Gain drift
	±10 V	<500 µV / 10 K	<0.01 % / 10 K
	±1 V	<50 µV / 10 K	<0.01 % / 10 K
	±100 mV	<5 µV / 10 K	<0.01 % / 10 K
Signal-to-noise ratio	>90 dB at 1 kHz	>120 dB at 1 Hz	
input impedance	> 100 MΩ		
Overtoltage protection	± 20 V (± 30 V for 5 sec)		

### Current Measurement

Input range	±25 mA (Internal shunt resistor 50 Ω)		
Margin of error	±5 µA		
Resolution	3 nA		
Long-term stability	<0.5 µA / 24 hrs	<5 µA / 8000 hrs	
Temperature drift	<1 µA / 10 K Offset drift	<0.03 % / 10 K Gain drift	

### Potentiometer Measurement

Resistance range	1 kΩ to 10 kΩ		
Long-term stability	<0.02 % / 24 hrs	<0.2 % / 8000 hrs	
Temperature drift	<0.0001 / 10 K Offset drift	<0.03 % / 10 K Gain drift	

### Resistance / RTD Measurement

Range and error	input range	margin of error	resolution
Resistance, 2-wire	100 kΩ	±100 Ω	12 mΩ
Resistance, 2-, 3- and 4-wire	4 kΩ	±1 Ω	0.5 mΩ
Resistance, 2-, 3- and 4-wire	400 Ω	±0.1 Ω	48 µΩ
Pt100, 2-, 3- and 4-wire	-200 to +850°C	±0.25°C	0.2 m°C
Pt1000, 2-, 3- and 4-wire	-200 to +850°C	±1°C	0.2 m°C
Sensor excitation	640 µA (< 4 kΩ) 15 µA (> 4 kΩ)		
Long-term stability	<10 mΩ / 24 hrs	<100 mΩ / 8000 hrs	
Temperature drift (range 400 Ω)	<10 mΩ / 10 K Offset drift	<0.03 % / 10 K Gain drift	

### Thermocouple Measurement

Range and error	Type	range	margin of error with CJC <sup>1</sup>
	Type B	400°C to 1820°C	< ±1.5 °C
	Type E, J, K	-100 to 1000°C	< ±0.7°C
	Type E	-270°C to 1000°C	< ±1°C
	Type K	-270°C to 1372°C	< ±1°C
	Type L	-200°C to 900°C	< ±0.7°C
	Type N	-100°C to 1000°C	< ±0.7°C
	Type N	-270°C to 1300°C	< ±1°C
	Type R, S	-50°C to 1768°C	< ±1.2°C
	Type T, U	-100°C to 400°C	< ±0.7°C
	Type T	-270°C to 400°C	< ±1°C
Input impedance	> 10 MΩ		
Long-term stability	<0.1°C / 24 hrs	<0.2°C / 8000 hrs	
Temperature drift	<0.2°C / 10 K Offset drift	<0.025% / 10 K Gain drift	
CJC uncertainty	<0.3°C		

<sup>1</sup> specifications are only valid with mains frequency rejection enabled

### Strain Gage Measurement

Bridge configuration(s)	resistive full-bridge (4-wire) resistive half-bridge (3-wire, with bridge completion terminal) resistive quarter-bridge 120 Ω or 350 Ω (3-wire, with bridge completion terminal)	
Accuracy class	0.05	
Allowable bridge resistance	>100 Ω	
Bridge excitation (nominal)	2.5 VDC	
Input range	±2.5 mV/V ±50 mV/V ±500 mV/V	
Long-term stability (range 2.5 mV/V)	<0.12 μV/V / 24 hrs	<1.25 μV/V / 8000 hrs
Temperature drift (range 2.5 mV/V)	<0.2 μV/V / 10 K Offset drift	<0.05 % / 10 K Gain drift

### Sensor excitation

Channels	4 (not galvanic isolated)
Voltage	3.3 V up to 24 V (Max. VS - 3V)
	Accuracy: ± 3 % @ 100 mA
	Resolution: 10 mV
Current limit	50 mA up to 100 mA
	Accuracy: ± 5 %
	Resolution: 100 μA
Load regulation	< 3 % @ 3.3 V up to 12 V < 1 % @ 12 V up to 24 V
Noise	< 5 mV (RMS)

# Q.brixx XE A107 SV

## Universal Measurement Module

### Analog to Digital Conversion

Resolution	24-bit
Sample rate	20 kHz per channel (thermocouple 10 Hz)
Modulation method	sigma-delta
Anti-aliasing filter	2 kHz, 3rd order
Digital filters	Infinite impulse response (IIR), low-pass, high-pass, Butterworth or Bessel (2nd, 4th, 6th or 8th order), frequency range 0.1 Hz to 1 kHz (adjustable via software)
Averaging	configurable or automatic according to the user-defined data rate

### Communication interface EtherCAT

Electrical standard	RS-485, 2-wire
Protocols	EtherCAT (LVDS)

### Input Power

Input voltage	10 to 30 VDC, overvoltage and overcurrent protection
Power consumption	2.5 W (approx.)
Input voltage influence	< 0.001 % / V
Sensor excitation VS	20 V up to 30 V

### Environmental Specifications

Operating temperature	-20°C to +60°C
Storage temperature	-40°C to +85°C
Relative humidity	5 - 95 % at 50°C (non-condensing)

### Remarks

Are subject to a warm-up period of at least 45 minutes

in a controlled electromagnetic environment<sup>1</sup>

With configuration: Low-pass 10Hz<sup>2</sup>

Specifications subject to change without notice

<sup>1</sup> according to EN 61326 2006: appendix B

<sup>2</sup> according to EN 61326 2006: appendix A

### Mechanical information

Material	Aluminum
Measurements (W x H x D)	30x 137 x 135mm
Weight	approx. 500 g
Protection class	IP40

### Ordering Information

Article number	804828
----------------	--------