



Features

- 15" Intel® Elkhart Lake J6412 Fanless Stainless Panel PC
- Support Win10 / Win11
- IP66/67/69K Full Sealed Enclosure
- 100% Waterproof Guarantee
- Brightness Control by OS
- Optional IP67 M12 Stainless Connectors
- Optional Cable Gland for External I.O.
- Customization Floor Stand Kits
- CE, FCC, VCCI Class B Certified

Specification

Product		WTP-8J66-15	
Main System	CPU	Intel® Elkhart Lake SoC Processors J6412, QC, 2.0~2.60 GHz, 10W	
	Graphic	Intel® Gen 11 UHD Graphics	
	Memory	Dual channel support 3200MHz DDR4 SODIMM socketx2, up to 32GB	
	OS Support	Win 10 / Win 11 (Option)	
Display	Size	15" 4:3	
	Resolution (pixel)	1024 x 768 (XGA)	
	Number of Colors	16.2M colors	
	View Angle (H/V)	160(H) / 150(V)	
	Brightness (cd/m ² , nit)	350	
	Contrast Ratio	800: 1 (Typ)	
Touch Panel	Type	Full flat resistive touch panel	Full flat p-cap touch
	Light Transmission	80 ± 5%	≥ 86%
	Hardness	≥ 3H	≥ 7H
	Lifetime	35M hours	100M times
Storage & Expansion	Storage	1 x 2.5" SATA HDD drive bay 1 x M.2 (M Key 2242/2260/2280) SATA3 & PCIe for SSD	
	Expansion	1 x PCIe x1 Gen3 1 x M.2 (E key 2230) w/PCIe x1 and shared USB2.0 for wireless, 1 x M.2 (B key,3042/3052) with PCIe x1/USB 3.2/USB2.0 SIM for 4G/5G 1 x SIM socket connected to M.2 key B	
I/O Ports	Configuration	STD. (M12 Connector)	Cable Gland (Max. 5 external I/O by proper grommet)
	USB	1 x M12 8pin for USB 1/2 (USB2.0) 1 x M12 8pin for USB 3/4 (USB2.0)	2 x USB 3.2 (Gen1) 2 x USB2.0
	COM	2 x M12 8pin/ RS232	RS232/RS422/RS485 x 2
	LAN	1 x M12 8pin for LAN (2.5 Gigabit)	1 x 1 Gigabit LAN 1 x 2.5 Gigabit LAN
	Audio	NA	2 x 3.5mm phone jack connector (Line-out, Mic-in)
	Video	NA	1 x HDMI 2.0b, 1 x VGA
	DC in	1 x M12 5pin DC power connector	
	Control Keys	Rear bottom: Power on /off	
Power	Power input	DC 12V~28V	
	Power adapter	AC 100~277V / 47 ~ 63 Hz / DC output 24V, 120W (IP68 PSU w/ PSE)	
	Power consumption	TBD W	
Environmental	Temperature	Operating Temperature 0~40°C (24V DC, IEC60068-2-56, HDD) 0~50°C (24V DC, IEC60068-2-56, SSD) Storage Temperature -20~60°C	
	Humidity	Operating & Storage: 10 ~ 90%, non-condensing	
	Water/Dust resistance	IP66 / NEMA4X / IP69K whole set /IK05	
Mechanical Characteristics	Housing	Stainless steel (SUS304), chassis type	
	Dimensions (Net: mm)	395 x 309.5 x 58	
	Weights (Net: kg)	8.4 kg	
	Mounting	VESA 100/100, Side mount (M6*2)	
Certification	CE (EMC) FCC Class B, Canada ICES-003 VCCI Class B		

WTP-8J66-15

Stainless Steel Panel PC

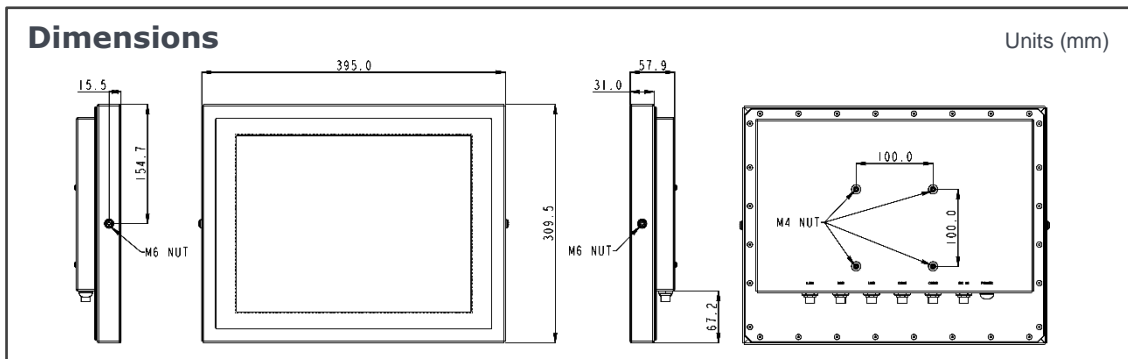

Major Options

Options	<ul style="list-style-type: none"> ① Wireless LAN or Wireless and BT kit (Easy Clean and Robust Antenna) ② Cable Gland for External I.O. ③ External 2 X LAN (Occupy 1 x COM), ④ Full Flat PCT Touch Screen IP69K ⑤ Stainless M12 connector ⑥ SUS316 Enclosure ⑦ IP67 ⑧ M12 (female) to M12 (male) DC power extension cable (2 meters length) ⑨ M12 (female) to stripped and tinned wires DC extension cable (1.2 meter length)
Accessory	<ul style="list-style-type: none"> ① Waterproof USB cable, cable length is 2 meters ② Waterproof LAN cable, cable length is 2 meters ③ Waterproof COM cable, cable length is 2 meters ④ DC input cable ⑤ Wall Mount & Table Mount Bracket
Customization	<ul style="list-style-type: none"> ① Sunlight readable optical bonding (Impact Protection Level: IK08) ② 1000 nit high brightness LCD ③ Roof for UV protection and sunlight readable, ④ 5W/2W Speaker ⑤ Barcode reader ⑥ Second HD for RAID 0,1 ⑦ COM + power 5V or 12V ⑧ TPM 2.0 ⑨ 5G module ⑩ DC-In connector x 1 (phoenix type 4pin), ⑪ Floor stand accessory (cable gland type) ⑫ M.2 SSD

Order Information

Item	Cooling	Description
WTP-8J66-15-Resis	Fanless	15" J6412 / DDR4 4G RAM / 512G SSD / Resistive touch
WTP-8J66-15-PCT	Fanless	15" J6412 / DDR4 4G RAM / 512G SSD / P-cap touch

I.O

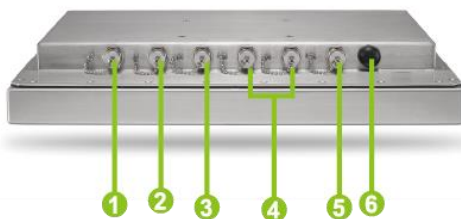

- ① Giga LAN
- ② USB 1/2
- ③ USB 3/4
- ④ COM x 2
- ⑤ DC-in
- ⑥ Power on/off

