

High temperature WELDABLE STRAIN GAUGES

series **AW**



AWM / AWMD / AWH / AWHU / AW / AWC / AWCH

These strain gauges have strain sensing elements fully encapsulated in corrosion-resisting metal tubes made of stainless steel or Inconel (except AW-6-350). The strain gauge backings are also made of the same material, and the gauges are installed by spot welding to metal specimens using a dedicated spot welder.

The maximum operating temperature is 800°C for the AWHU. These gauges are suited to measurement in high temperature harsh environments such as underwater or gas-filled atmosphere, or for long term. The AWC-2B and AWCH-2 are available in 1-Gauge 4-Wire configuration.

<p>AWM -196 ~ +300°C Quarter bridge 3-wire</p> <p>AWM-8-1A Gauge base : Inconel 600 AWM-8-1B Gauge base : SUS304</p>	<p>AW-6 -196 ~ +300°C Quarter bridge 3-wire</p> <p>AW-6-350-11-4FB01LT</p>
<p>AWMD -196 ~ +800°C for dynamic strain Full bridge</p> <p>AWMD-5 Gauge base : Inconel 600 AWMD-8 Gauge base : Inconel 600</p>	<p>AWC -20 ~ +100°C</p> <p>AWC-2B-11-3LQSA 1-Gauge 4-Wire AWC-8B-11-3LTSB Quarter bridge 3-wire</p>
<p>AWH -196 ~ +600°C for static strain Full bridge -196 ~ +650°C for dynamic strain Full bridge</p> <p>AWH-4-7A/AWH-8-7A Gauge base: Inconel 600 AWH-4-7B/AWH-8-7B Gauge base: SUS321</p>	<p>AWCH -196 ~ +200°C 1-Gauge 4-Wire</p> <p>AWCH-2-11-MI2L-05LQSA Gauge base: SUS304</p>
<p>AWHU -196 ~ +800°C Full bridge</p> <p>AWHU-5 Gauge base: Inconel 600 AWHU-8 Gauge base: Inconel 600</p>	

AW series coding system

	(1)	(2)	(3)	(4)	(5)	(6)	(7)	(8)
AWM	-8-	1	B			-2		-17.0
AWMD	-5-		A	KM		-2	(6F)	-1.6Hz*
AWMD	-8-		A			-2		-1.6Hz*
AWH	-8-	7	A			-2		-11.0
AWHU	-5-	9	A	KM		-2	(6F)	-12.7

*: High-pass filter only for AWMD Either one available among 1.6, 7.2 or 16Hz.

(1) Type	(2) Gauge length	(3) Temperature compensation range	(4) Gauge base*1	(5) Option
AWM : static/dynamic 300°C	8: 8mm	0 : -196°C ~ RT 1 : RT ~ +300°C	A: Inconel 600 Applicable thermal expansion coefficient of 11ppm/°C or closer	E: Ground earth F: Compression fittings
AWMD : dynamic only 800°C	5: 5mm 8: 8mm	2 : RT ~ +350°C 3 : RT ~ +400°C	B: AWH SUS321 AWM SUS304 Applicable thermal expansion coefficient of 17ppm/°C or closer	K: Narrow gauge width W=3mm (5mm standard) M: Small junction type of sleeve B φ 2.0mm L=20mm AWHU and AWMD-5 are normally provided with small junction
AWH : static 600°C : dynamic 650°C	4: 4mm 8: 8mm	4 : RT ~ +450°C 5 : RT ~ +500°C		P: NDIS type plug attached*2 R: Bend of gauge backing or pipe
AWHU : static/dynamic 800°C	5: 5mm 8: 8mm	6 : RT ~ +550°C 7 : RT ~ +600°C 8 : RT ~ +650°C 9 : RT ~ +800°C 10 : Others NB1: Dynamic use AWMD is not applicable. NB2: RT Room temperature		Z: Filter-less (AWMD)

*1: Select code A for thermal expansion coefficient of 11ppm/°C or closer, or B for coefficient of 17ppm/°C

*2: For option code P, NDIS plug is attached to the end of cables following Temperature-compensation board or High-pass filter.



AWM / AWMD / AWH / AWHU / AW / AWC / AWCH

(6) MI cable	(7) Supplied cable length	(8) Temperature compensation materials or High-pass filter
2: φ 1.6mm 2m Core cable of heat-resistive copper	No marks: φ 4.1mm shielded vinyl cable of 0.5m Except for standard length, required length is given in bracket Example: 4.5m long to (4.5)	Materials available for temperature-compensation 10.9: SUS430 or equivalent 11.0: Mild steel (ferritic) or equivalent 12.7: INCONEL 600 or equivalent 17.0: SUS304 or equivalent
	(6F): φ 1.6mm shielded fluoroethylene propylene cable (FEP) of 0.5m for AWHU-5/-8, AWMD-5 Except for standard length, required length is given after suffix 6F. Example: 4.5m long to (6F4.5)	High-pass filter for only AWMD 1.6: 1.6Hz 7.2: 7.2Hz 16 : 16Hz

Examples of option

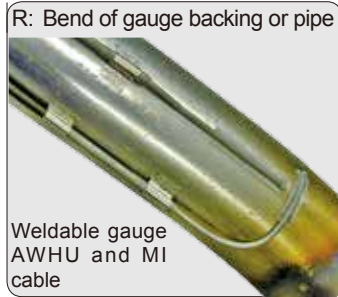
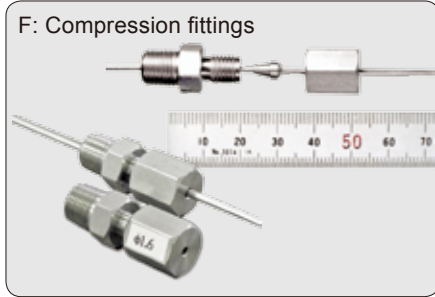

Stainless steel ribbon
Designed to fix cables
Size 5mm x 10m x 0.08mm
10mm x 10m x 0.08mm

Correction for strain gauge height

Unlike adhesive-bonding strain gauges, the sensitive elements in weldable strain gauges sit some distance above the test specimen surface. As a result, the sensitivity to torsion and bending is different. Particularly in bending tests for thin boards, the following equation must be used to correct the sensitivity.

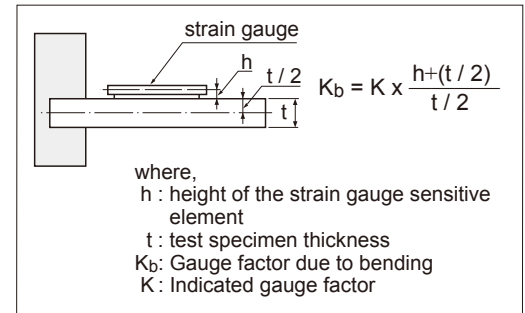

Using resistance welding to install weldable strain gauges

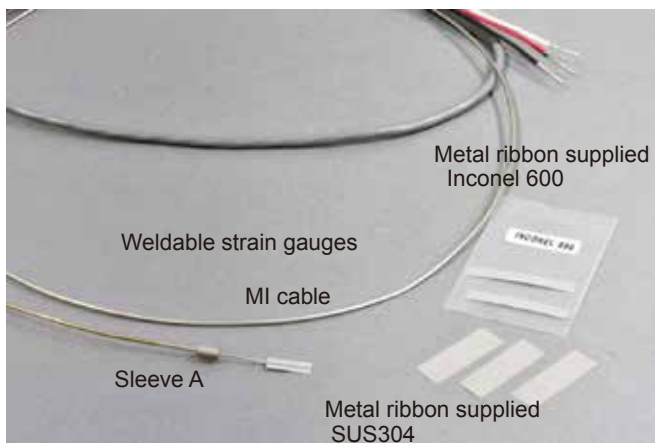

Weldable strain gauges include Metal ribbon of Inconel 600 or SUS304 for trial welding and securing sleeve A and MI cable. To install weldable strain gauges, use Spot Welder W-50RB together with the metal ribbon.

- Metal ribbon supplied :
- Inconel 600 2 pcs. 30~50 x 5 x 0.08mm
 - SUS304 3 pcs. 32 x 11 x 0.08mm

Trial Welding
The metal ribbon is used to adjust the welding power of the Spot Welder. If cracks or a hole appear in the ribbon, reduce the power. If the ribbon is unmarked, increase the power.

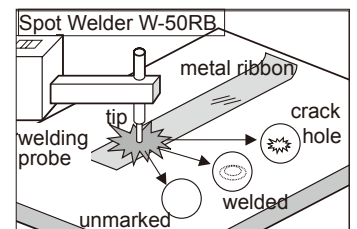

Securing Sleeve A
Align the center of the strain gauge with the marks and press down on the gauge so that it is flush against the test specimen. Sleeve A is secured using the metal ribbon as illustrated.

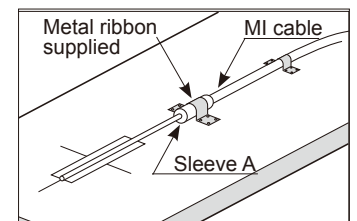

Securing MI cable
To avoid load being placed on secured sleeve A, secure the MI cable with the metal ribbon. To avoid undue strain on the MI cable, secure the cable between the gauge and connecting terminal in a gentle curve.

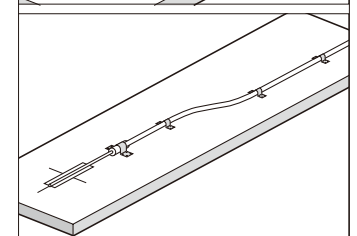

High temperature WELDABLE STRAIN GAUGES

series **AW**



Weldable Strain Gauges AWM / AWMD

AWM-8 Quarter bridge with 3-wire method

Minimum order is 1 gauge.

The AWM is usable up to 300°C for both static and dynamic strain measurement. The backing material is available in Inconel 600 or SUS304 which should be selected according to the test specimen material.



Operating temperature range



Temperature compensation range



Type		Gauge length (mm)	Gauge base		Operating temperature <Temperature compensation range>	Test specimen	Resistance in Ω
			Dimension (mm)	Materials			
Static/Dynamic strain measurement	AWM-8-1A-2-11.0	8	L16xW5xT0.7	Inconel 600	For static/dynamic use -196~+300°C <Room-temperature ~ +300°C>	Mild steel or equivalent SUS304 or equivalent	120
	AWM-8-1B-2-17.0			SUS304			

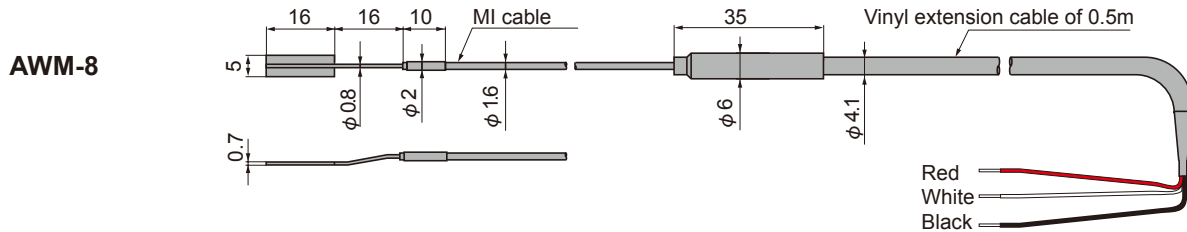

AWMD-5 / AWMD-8 for dynamic strain measurement only Full bridge

Minimum order is 1 gauge.

The AWMD is applicable up to 800°C and it is dedicated to dynamic strain measurement. A high pass filter is a standard accessory. Using the high pass filter, unnecessary direct current component or low frequency component (thermal output, drift etc.) in the measurement signals can be neglected. The DC exciting Dynamic Strainmeter (DC-96A/-97A) or the Smart Dynamic Strain Recorder DC-204R, Multi-Recorder TMR-200 should be used for the measurement.



Operating temperature range



Temperature compensation range Not available

Type		Gauge length (mm)	Gauge base		Operating temperature <Temperature compensation range>	Test specimen	Resistance in Ω
			Dimension (mm)	Materials			
Dynamic strain measurement	AWMD-5-AKMS-2(6F)-1.6Hz*	5	L10xW3xT0.7	Inconel 600	-196~+800°C < N/A >	Inconel 600 or equivalent	60
	AWMD-8-A-2-1.6Hz*	8	L16xW5xT0.7	Inconel 600			120

*: High-pass filter only for AWMD Either one available among 1.6, 7.2 or 16Hz.

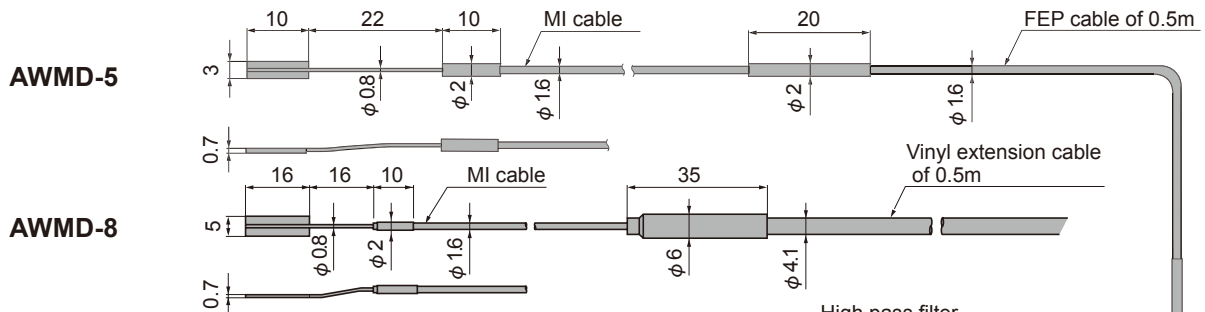

Plug-in NDIS connector of TML Dynamic Strainmeter

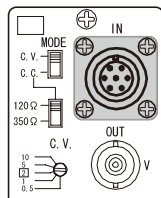

TML Bridge Box Full bridge wiring or NDIS plug connector

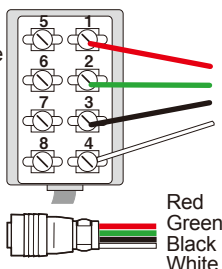

Option code P for NDIS plug connector available with AWMD/AWH/AWHU attached to Temperature-compensation board or High-pass filter



Weldable Strain Gauges AWH / AWHU

AWH-4 / AWH-8 Full bridge

The backing material is available in Inconel 600 or SUS321 which should be selected according to the test specimen material. Although the gauge has a half bridge construction consisting of active and dummy gauges, the measurement is made by the full bridge method using the supplied temperature compensation circuit board. The maximum operating temperature is 600°C for static strain measurement and 650°C for dynamic strain measurement.



Minimum order is 1 gauge.

Operating temperature range
 Static strain measurement -196°C ~ +600°C
 Dynamic strain measurement -196°C ~ +650°C
 Temperature compensation range
 Static strain measurement RT ~ +600°C
 Dynamic strain measurement RT ~ +650°C

Type	Gauge length (mm)	Gauge base		Operating temperature <Temperature compensation range>	Test specimen	Resistance in Ω
		Dimension(mm)	Materials			
AWH-4-7A-2-11.0	4	L10xW3xT0.8	Inconel 600	For static use -196~+600°C <Room-temperature ~ +600°C>	Mild steel or equivalent	60
AWH-4-7B-2-17.0			SUS321		SUS304 or equivalent	
AWH-8-7A-2-11.0	8	L16xW5xT0.8	Inconel 600	For dynamic use -196~+650°C <Room-temperature ~ +650°C >	Mild steel or equivalent	120
AWH-8-7B-2-17.0			SUS321		SUS304 or equivalent	

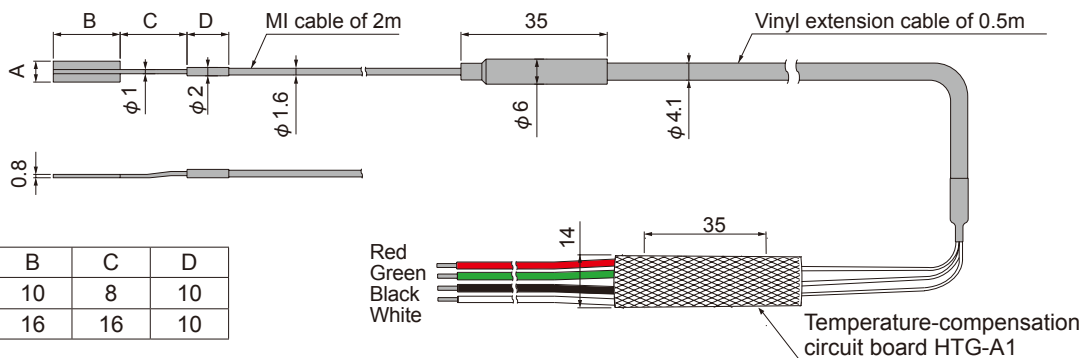

Type	A	B	C	D
AWH-4	3	10	8	10
AWH-8	5	16	16	10

AWHU-5 / AWHU-8 Full bridge

These gauges are usable up to 800°C for both static and dynamic strain measurement. Although the gauge has a half bridge construction consisting of active and dummy gauges, the measurement is made by the full bridge method using the supplied temperature compensation circuit board. The gauge base, junction part and cable of these gauges are constructed small as a standard specification and the gauges are suited for being mounted on a narrow or a curved part.



Minimum order is 1 gauge.

Operating temperature range -196°C ~ +800°C
 Temperature compensation range RT ~ +800°C

Type	Gauge length (mm)	Gauge base		Operating temperature <Temperature compensation range>	Test specimen	Resistance in Ω
		Dimension (mm)	Materials			
Static/Dynamic measurement	AWHU-5-9AKM-2(6F)-12.7	5	L10xW3xT0.8	For static/dynamic use -196 ~+800°C <Room-temperature ~+800°C >	Inconel 600 or equivalent	60
	AWHU-8-9AKM-2(6F)-12.7	8	L16xW3xT0.8			120

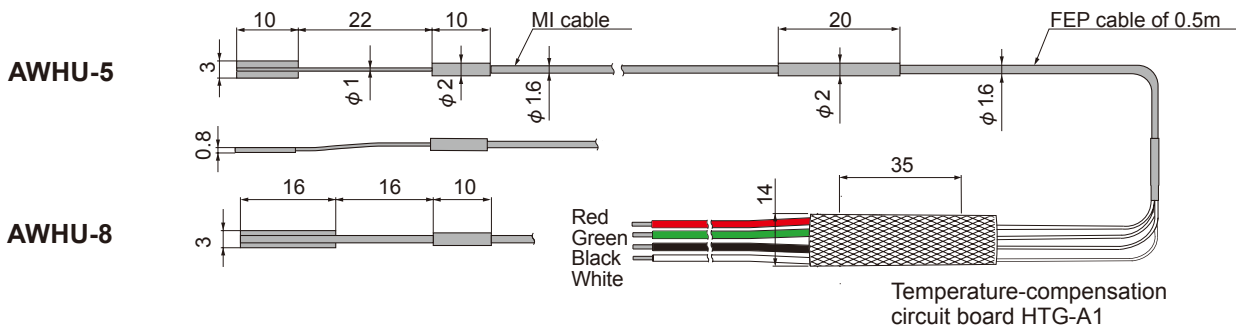

High temperature WELDABLE STRAIN GAUGES

series **AW**



Weldable Strain Gauges AW / AWC / AWCH

These gauges have corrosion-resisting stainless steel backing with thickness of 0.08mm. They are easily installed by using the dedicated spot welder W-50RB.

AW-6-350-11-4FB01LT Quarter bridge with 3-wire method

Minimum order is 5 gauges.

These gauges are suited for strain measurement in high temperature up to 300°C, for measurement of specimen to which adhesion is not applicable or for long term measurement.

Operating temperature range
 -196°C +300°C
 Temperature compensation range
 +10°C +100°C

Type	Gauge length (mm)	Gauge base		Operating temperature <Temperature compensation range>	Test specimen	Resistance in Ω
		Dimension(mm)	Materials			
AW-6-350-11-4FB01LT	6	L24xW5	SUS304	-196~+300°C <+10 ~ +100°C>	Mild steel	350

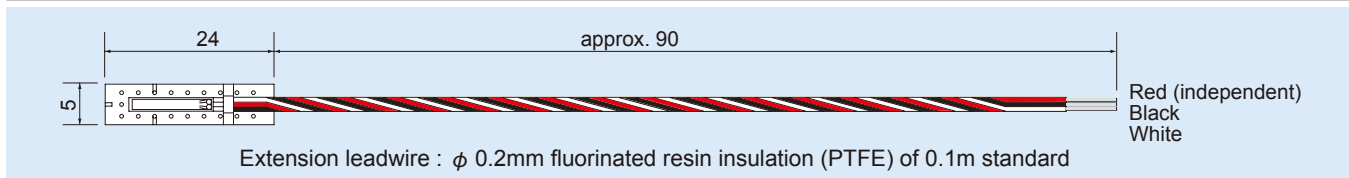

AWC-2B-11-3LQSA 1-Gauge 4-Wire system

AWC-8B-11-3LTSB Quarter bridge 3-wire method

Minimum order is 1 gauge.

These gauges are fully encapsulated in a stainless steel tube. It enables long term strain measurement in harsh environment.

Operating temperature range
 -20°C +100°C
 Temperature compensation range
 0°C +100°C AWC-2B-11-3LQ
 +10°C +100°C AWC-8B-11-3LT

Type	Gauge length (mm)	Gauge base		Operating temperature <Temperature compensation range>	Test specimen	Resistance in Ω
		Dimension(mm)	Materials			
AWC-2B-11-3LQSA	2	L16xW5xT0.5	SUS304	-20~+100°C <0 ~ +100°C >	Mild steel	120
AWC-8B-11-3LTSB	8	L28xW5xT1		-20~+100°C <+10 ~ +100°C >		

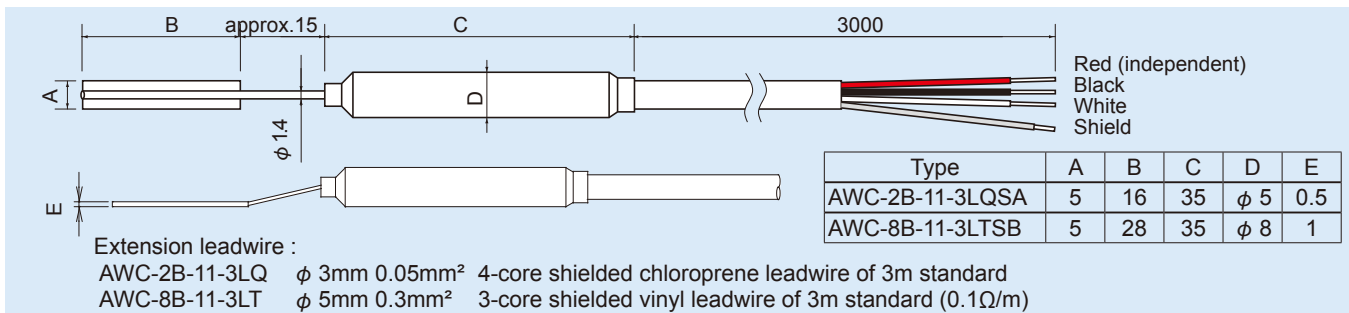

AWCH-2-11-MI2L-05LQSA 1-Gauge 4-Wire system

These gauges are fully encapsulated in compact size of stainless steel tube. These are designed for only 1-Gauge 4-Wire system with our data logger and can measure up to 200°C.

Operating temperature range
 -196°C +200°C
 Temperature compensation range
 0°C +150°C

Type	Gauge length (mm)	Gauge base		Operating temperature <Temperature compensation range>	Test specimen	Resistance in Ω
		Dimension(mm)	Materials			
AWCH-2-11-MI2L-05LQSA	2	L16xW5xT0.5	SUS304	-196~+200°C <0 ~ +150°C >	Mild steel	120

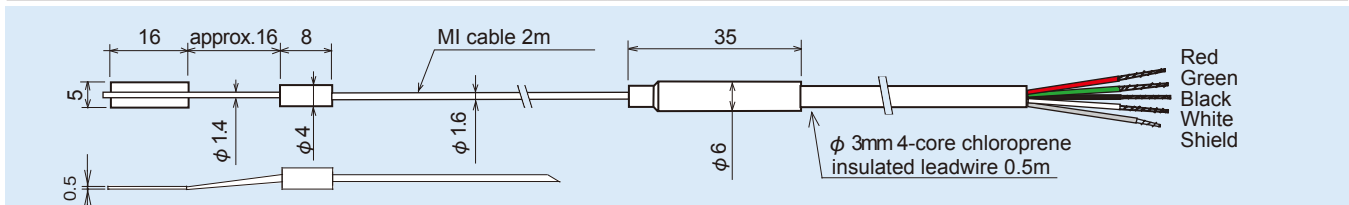



High temperature WELDABLE STRAIN GAUGES series AW

SPOT WELDER W-50RB



This is a capacitive charge spot welder used for installing weldable strain gauges and fixing leadwires. The welding energy is controlled in 2 ranges of 1~10/5~50 watt second continuously, and a stabilizing circuit cancels the effect of changes in the power source voltage. As projecting parts such as electrical cables are packed inside, these are extremely convenient for field applications.

SPECIFICATIONS

Welding energy	1~10 watt sec./5~50 watt sec. continuous 60 watt sec. Max. (110Vac 50Hz)
Output voltage	approx. 32V Max.
Output pulse width	approx. 5 msec.
Repetition use	2 welds/sec. at 50 watt sec.
Rated output	20 min./1.5 welds/sec. at 50 watt sec.
Weldable probe	III type probe
Welding force	4.9~19.8N
Welding tip	Arm φ 3mm, Nose φ 1mm
Cable length	2m
Operation environment	0~+50°C 85%RH or less (no condensation allowed)
Power source	90~110Vac., 50/60Hz 550VA peak(160msec.), 210VA/2 welds/sec.
Dimensions	300(W) x 195(H) x 195(D) mm
Weight	13kgs.
Standard accessory	
Operation manual	1
AC power cable (CR-01)	1
Welding tip	3
Protective cap	2
Abrasive paper (#400)	5
Carrying belt	1
Hexagon head wrench	1

Examples of installation

Installing a weldable gauge

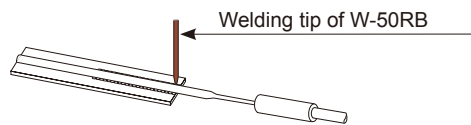

Fixing a MI cable

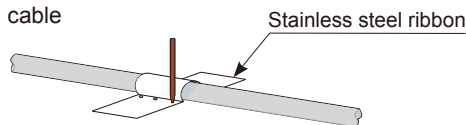

Fixing a fluorinated insulated cable

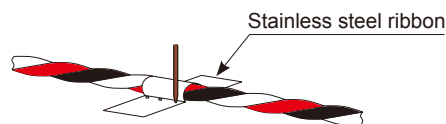

INDIVIDUAL TEST DATA

AWM, AWH and AWHU are always examined and supplied with individual test data including serial number, gauge factor, thermal output curve, bridge configuration, etc.

CAPACITATED HIGH TEMPERATURE STRAIN GAUGE AWH GAUGE-TEST DATA

Serial No.: H1820K-01

SPECIFICATIONS Gauge type: AWH-5-7A-2-11.0 Serial No.: H1820K-01 Gauge Factor: Original G.F. K ₀ = 3.75 Adjusted G.F. K ₀₂₀ = 3.52 Gauge resistance at room temperature: Dummy element R _d = 111.100 Ω Active element R _a = 120.886 Ω Object material: Equivalent to Mild Steel Compensation: Temperature range 20 ~ 600 °C Length: 2 m, Calibrated with heated 1 m MI cable: Temperature R ₀₂ = 5.6 Ω Compensation resistor: Balancing R _{bal} = 3.2 Ω Sensitivity shift: -310 ppm/°C Wiring: The supplied temperature compensation circuit board HTG-A1 includes all of temperature compensation, balance and fixed resistors. Connect the end lead wires of the gauge to TML readout instrument or its switching box in order of Red, Green, Black and White in the same manner as TML transducer connection.	CHARACTERISTICS
--	----------------------------

Temperature (°C)	Heated 0-meter Thermal Output (µm/m)	Heated 1-meter Thermal Output (µm/m)	Heated 2-meter Thermal Output (µm/m)	
21	0	1.405	0	1.405
103	-152	1.405	-149	1.507
202	-263	1.405	-253	1.752
300	-299	1.405	-235	1.956
400	-263	1.405	-243	2.156
500	-150	1.405	-124	2.352
599	30	1.405	67	2.545

Correction at G.F. = K₀₂₀

Destination of HTG-A1 Bridge and Color Code of lead Wires

N.B. Please make sure that both serial No.'s, marked on the end lead wire and HTG-A1 temperature compensation circuit board are the same.

TEMPERATURE STRAIN GAUGE AWHU GAUGE-TEST DATA

Serial No.: H1825C-01

SPECIFICATIONS Gauge type: AWHU-5-7A-2-11.0 Serial No.: H1825C-01 Gauge Factor: Original G.F. K ₀ = 2.08 Adjusted G.F. K ₀₂₀ = 2.05 Gauge resistance at room temperature: Dummy element R _d = 113.057 Ω Active element R _a = 120.688 Ω Object material: Inconel600 Compensation: Temperature range 20 ~ 800 °C Length: 2 m, Calibrated with heated 1 m MI cable: Temperature R ₀₂ = 5.6 Ω Compensation resistor: Balancing R _{bal} = 16.7 Ω Sensitivity shift: -310 ppm/°C Wiring: The supplied temperature compensation circuit board HTG-A1 includes all of temperature compensation, balance and fixed resistors. Connect the end lead wires of the gauge to TML readout instrument or its switching box in order of Red, Green, Black and White in the same manner as TML transducer connection.	CHARACTERISTICS
--	----------------------------

Temperature (°C)	Heated 0-meter Thermal Output (µm/m)	Heated 1-meter Thermal Output (µm/m)	Heated 2-meter Thermal Output (µm/m)	
21	0	1.405	0	1.405
103	-152	1.405	-149	1.507
202	-263	1.405	-253	1.752
300	-299	1.405	-235	1.956
400	-263	1.405	-243	2.156
500	-150	1.405	-124	2.352
599	30	1.405	67	2.545

Correction at G.F. = K₀₂₀

Destination of Bridge and Color Code of lead Wires

N.B. Please make sure that serial number marked on the end of lead wire and temperature compensation circuit board is the same.